

Devices for creating art

Toolkit for the Design and Implementation of

LEARNSCAPES

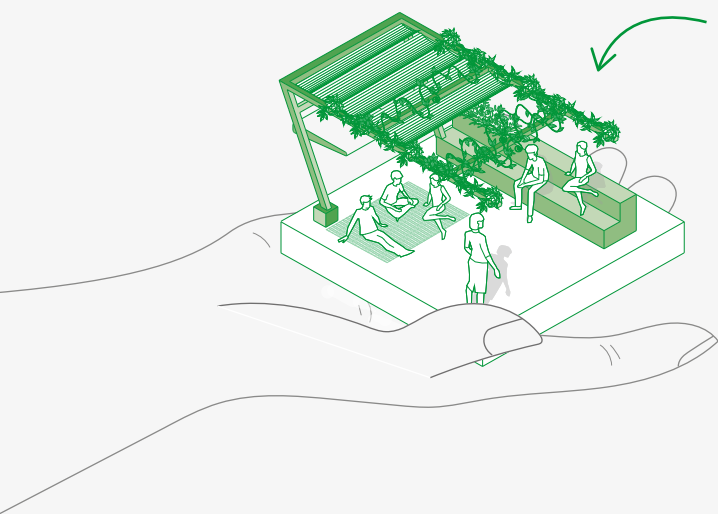

Devices for learning

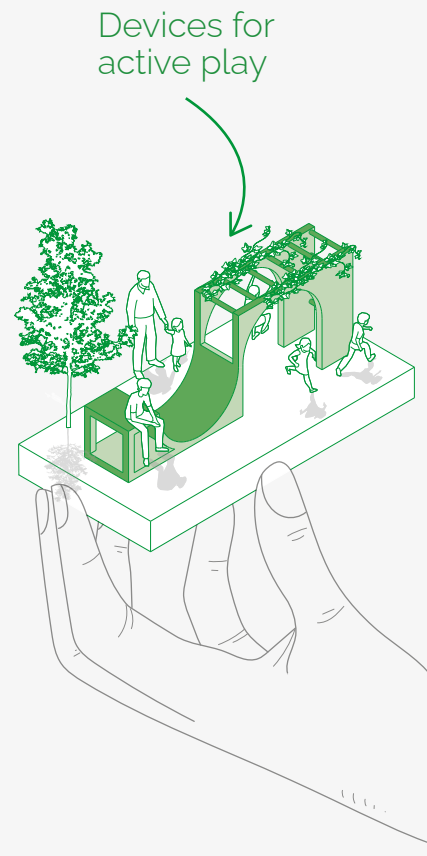

Devices for active play

**Toolkit for the Design and Implementation
of LEARNSCAPES**

This document was prepared for:
UNACEM



Toolkit for the Design
and Implementation of

LEARNSCAPES



Introduction

At Cemento SOL, our purpose is to improve people's quality of life through good construction. Staying true to that purpose, we decided to focus on the education sector in order to improve students' quality of life through a courtyard that enables the development of their social skills.

Why? Because these skills are just as important for the future success of our boys and girls as intellectual skills, and they develop spontaneously in the school courtyard. However, the current layout of most courtyards in Peru does not allow this.

As a UNACEM brand that believes in the power of cement as a driver of development, we cannot overlook this great opportunity to revolutionize school courtyards and create a positive change in the future of the country.

1

Context

After analyzing different school courtyards, we identified recurring design and structural problems. These serious shortcomings prevent certain activities that are fundamental to the development of students' social skills from taking place in the courtyard. This chapter explores in detail the challenges and the current context of school courtyards, laying the foundation for their transformation.

Current state

Students express the need for more spaces in school courtyards where they can interact, especially areas that offer protection from the sun and rain. Currently, in many courtyards, rainfall wets the entire surface, making it slippery and dangerous.

The areas where they spend the most time are usually those with concrete benches, because students perceive them as a refuge from both balls being kicked around and the sun. Although they appreciate their courtyards, they would like to see several improvements. During workshops, some students said they would like to include more color in the spaces and add tables and chairs for board games.

In most courtyards, sports slabs dominate the space and are used mainly for soccer, an activity that occupies almost the entire courtyard and limits students to a restricted, single-use experience of the space. However, other activities take place around these courts, such as elastic-band games, breaks, conversations, reading comics, and more. In addition, school courtyards are important spaces for social activities such as field days, tournaments, school parades, and cultural events.

These spaces are usually dominated by a single activity, mainly soccer, involving only some students.

Between **70%** and **80%** of the regular school day, school courtyards **remain unused.**

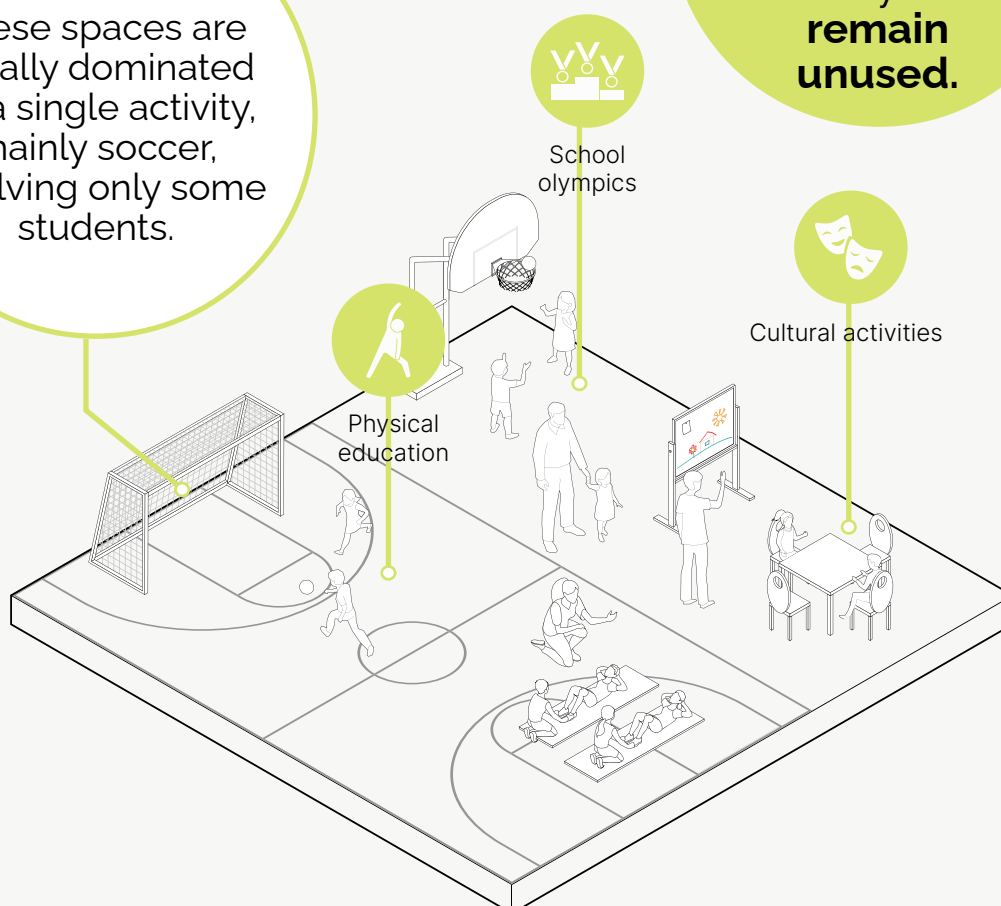

Main problems identified in school courtyards

1. Deterioration of infrastructure.



2. Lack of diversity in recreational spaces.



3. Shortage of shaded areas.

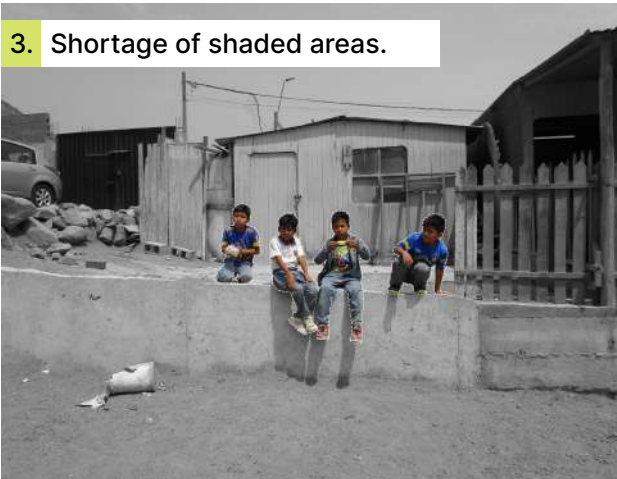

4. Low accessibility for people with disabilities.



5. Lack of vegetation.



6. Exclusionary design focused on a single sport (soccer).



General elements identified in school courtyards



2

Activities

As part of the analysis carried out in educational facilities, different activities that students perform in school courtyards were identified. To optimize the design and operation of the school courtyard, seven main activities and three types of zones were defined according to the level of activity that takes place in each one.

Activities identified in participatory design workshops

To optimize the design and functioning of the school playground, **seven main activities** and **three types of zones** were identified, classified according to the level of activity that takes place in each. These zones reflect the diversity of playground uses and their importance in the holistic development of students, promoting a balance between movement, creativity, and rest.









Each zone is designed to respond to different dynamics and needs, optimizing the functionality of the school space and ensuring its use by the entire educational community.











Device configuration rules in the school courtyard based on zones and activities

Within our courtyard, there are twenty-eight devices, each representing a specific activity that takes place in the space. To ensure a safe, functional, and inclusive design, it is important to follow configuration rules that respect the usage dynamics of each zone and activity. Below are the guidelines for arranging the devices:

Compatibility between zones and activities

Zones / Activities	Active zone (Physical education, active play)	Semi-active zone (Create art, spend time, learn)	Zona tranquila (Rest, eat)
Active zone	 Compatible with each other	 Avoid direct proximity	 Do not place nearby
Semi-active zone	 Avoid direct proximity	 Compatible with each other	 Can be placed nearby
Quiet zone	 Do not place nearby	 Can be placed nearby	 Compatible with each other

Specific configuration rules

Placement and separation of devices	<ul style="list-style-type: none">  Place active play and sports devices in areas away from rest and eating zones.  Avoid placing climbing structures or ramps near eating areas or quiet zones.  Create transitions with vegetation, benches, or low walls between active and quiet zones.  Do not mix devices from active zones with learning or art devices, to prevent interruptions and accidents.
Safety and accident prevention	<ul style="list-style-type: none">  Include physical barriers such as planters or bleachers between play areas and rest or eating zones.  Do not place ball sports devices facing rest or eating areas.  Use impact-absorbing materials in play areas to minimize risks.  Do not install climbing devices without a nearby cushioning area.  All devices should have rounded edges to prevent injuries from sharp corners.

Functionality and flow of the space	<ul style="list-style-type: none"> ✔ Design a fluid circulation between zones without interruptions. ✘ Avoid concentrating devices in a single area; distribute them evenly across the courtyard. ✔ Ensure accessibility for all students, including ramps and connections between devices. ✘ Do not block views or main pathways with structures that are too tall or enclosed.
Universal accessibility	<ul style="list-style-type: none"> ✔ Integrate accessible pathways that connect all zones and avoid architectural barriers. ✔ Incorporate ramps and non-slip surfaces to facilitate access for all students. ✘ Avoid steps without an accessible alternative near commonly used devices.
Thermal comfort	<ul style="list-style-type: none"> ✔ Place pergolas and vegetation in quiet zones to provide shade and thermal comfort. ✔ Orient rest and eating devices toward areas with natural or artificial shade. ✘ Do not place metal structures in sun-exposed areas without thermal protection.
Signage and organization	<ul style="list-style-type: none"> ✔ Include clear signage to define play, rest, and learning zones. ✔ Use differentiated colors and textures on the ground to mark each zone. ✘ Do not overcrowd an area with multiple devices without proper signage, to avoid confusion.
Maintenance and durability	<ul style="list-style-type: none"> ✔ Plan for durable, easy-to-maintain materials based on use and exposure to weather conditions. ✔ Design proper drainage for devices exposed to rain to prevent water accumulation. ✘ Do not place untreated wooden devices in humid areas, as they may deteriorate quickly.

The proper configuration of devices in school courtyards not only ensures a **safe and functional environment**, but also **enhances the student experience by promoting learning, creativity, social interaction, and other activities essential for the development of their social skills**. By applying these guidelines, we ensure a balanced distribution that respects the dynamics of each zone, minimizes risks, and improves thermal comfort and accessibility. **A well-designed courtyard becomes a vibrant, inclusive, and dynamic space where every student can find their place to play, learn, and rest.**

3

Devices

In this section of the **toolkit**, you will learn how to build a device and find a catalog of options adapted to the activities and zones you want to configure in your school courtyard.

Elements needed to build a device

1

BASE

Structural concrete base that provides stability and resistance to the installation.

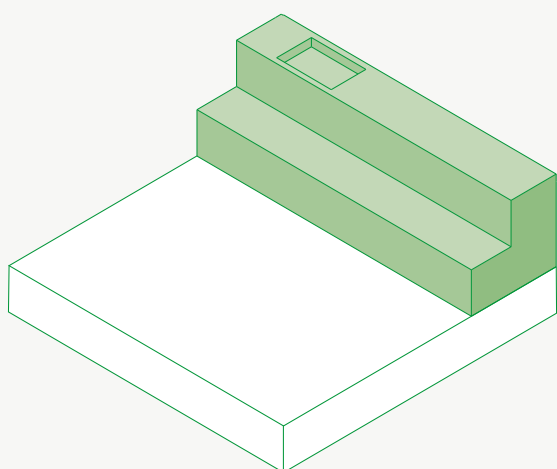

2

STRUCTURE

Main support that guarantees the safety and durability of the device.

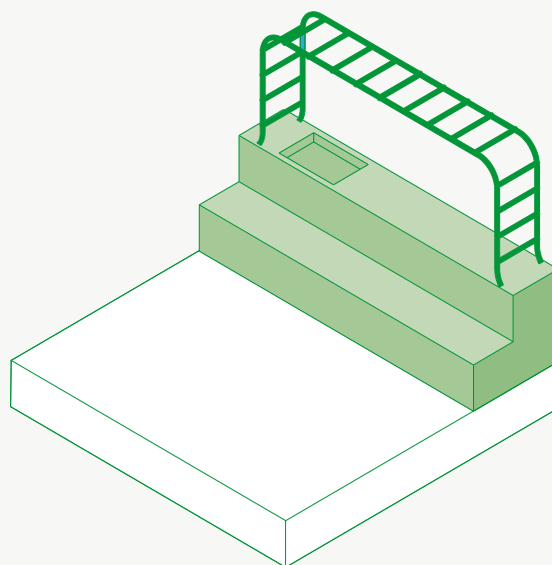

3

COVERING

Elements that provide shade and protection, such as fabric, metal mesh, or translucent materials.

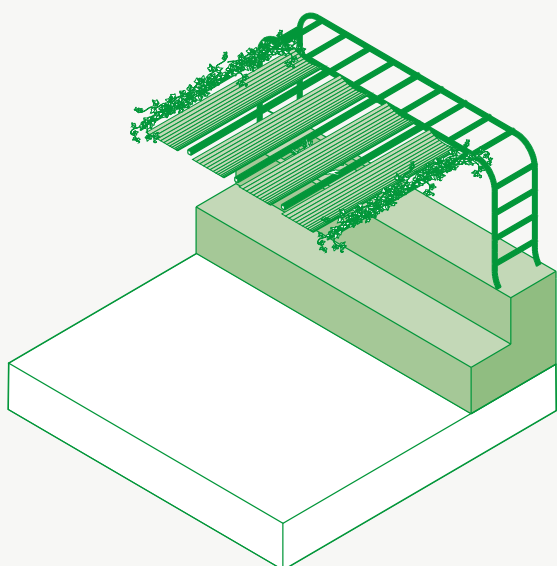

4

FLOORING

Appropriate finishes depending on the activity, such as rubber, wood, synthetic grass, or polished concrete.

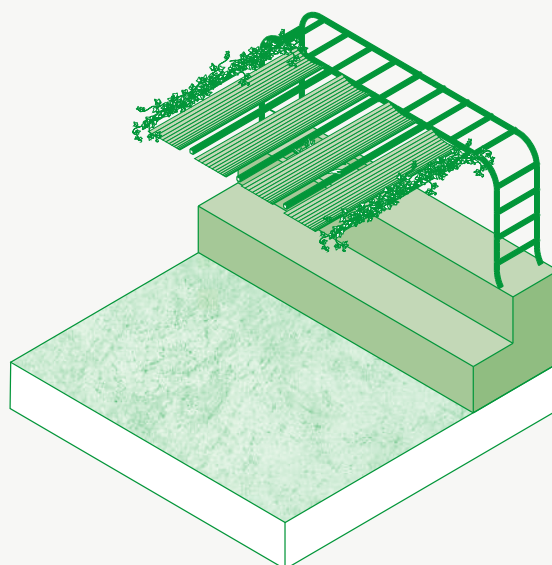

Steps to build a device

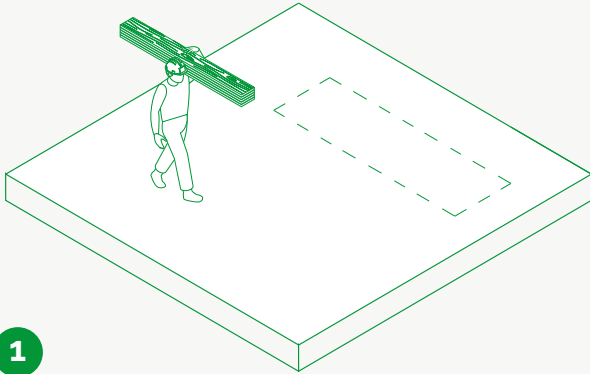

1

Layout and delimitation of the space

Identify and mark the area where the device will be installed, ensuring proper leveling and alignment for stability and functionality.

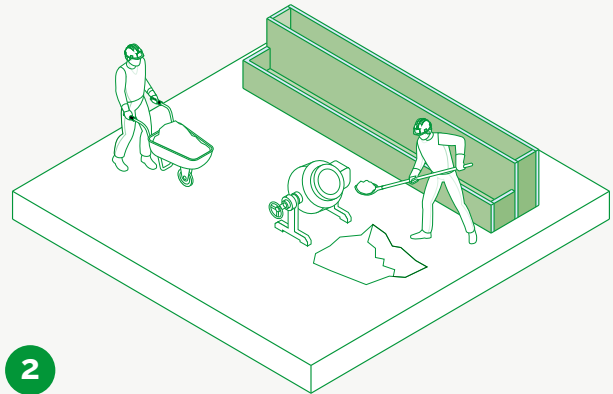

2

Formwork of the structural base

Place temporary molds that define the shape and dimensions of the base, ensuring construction precision.

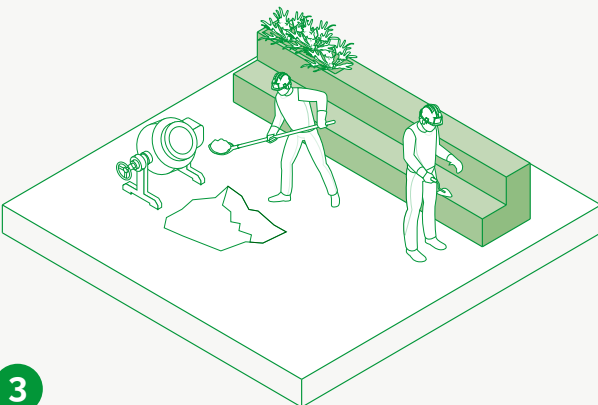

3

Concrete pouring

Pour and level the concrete to obtain a solid and resistant base, ensuring durability and long-term stability.

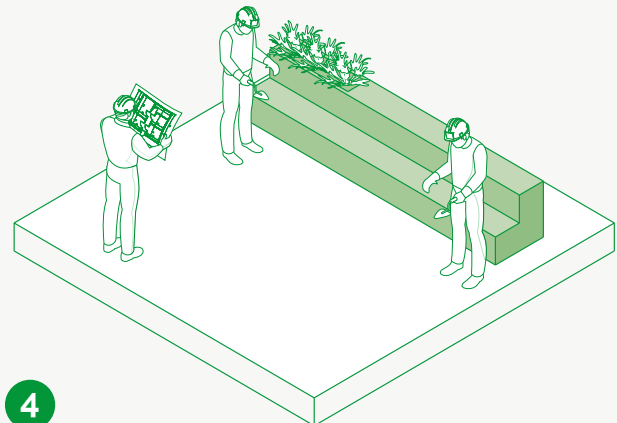

4

Finishing and rounding of the concrete base

Polish and round the concrete to improve resistance, texture, and appearance, avoiding rough or irregular surfaces.



5

Installation of the metal structure

Assemble and secure the structural elements that support the covering and other components, guaranteeing safety and functionality.



6

Placement of the mixed covering

Install a partial covering that combines metal mesh with climbing plants to provide shade and improve thermal comfort.

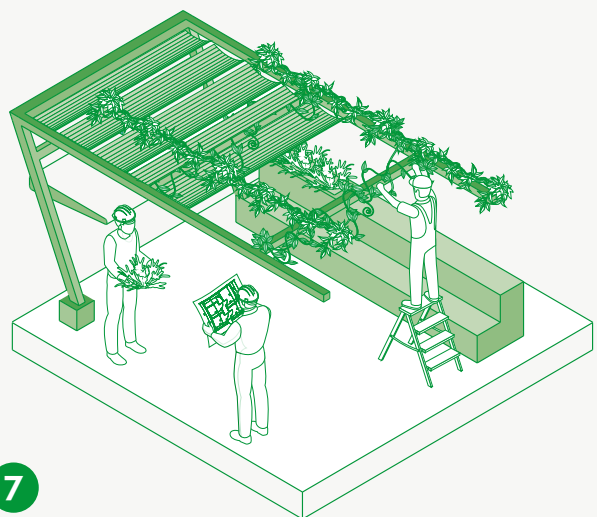

7

Incorporation of vegetation

Integrate plants and vines as part of the design, contributing to environmental improvement, temperature regulation, and well-being.

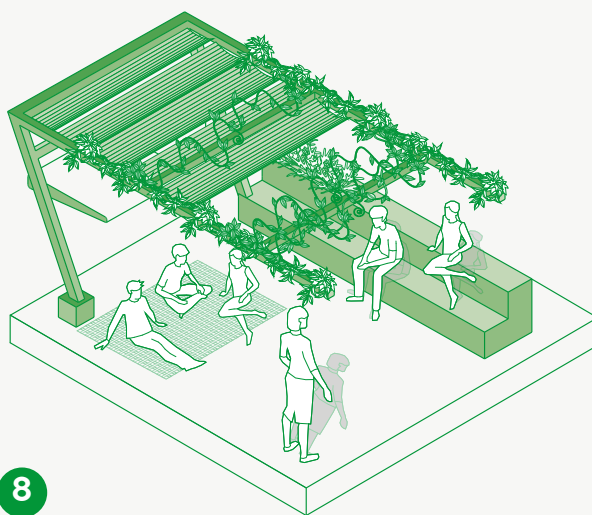

8

Use and appropriation of the space

Enable the device for its main purpose—supporting outdoor learning and promoting educational activities in contact with nature.

Devices

Below are the devices and the device matrix used to configure educational courtyards, based on the classification of activities and zones identified in school courtyards.

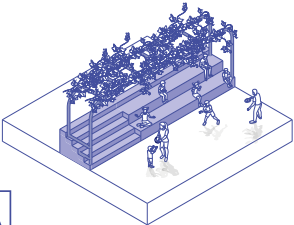
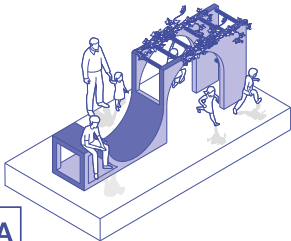
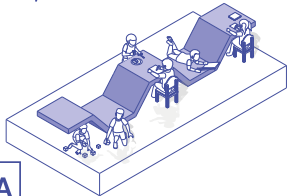
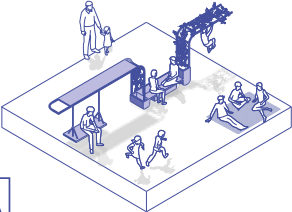
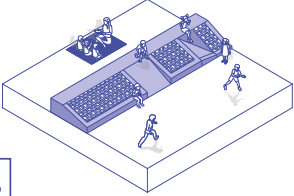
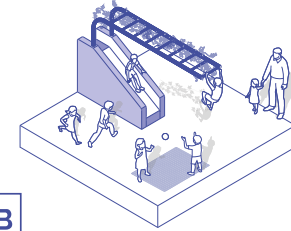
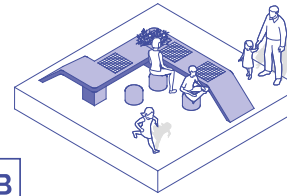
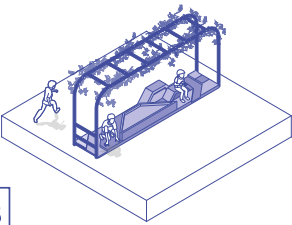
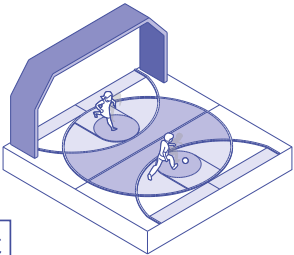
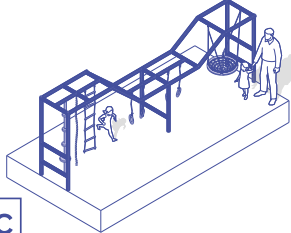
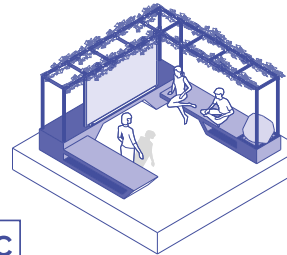
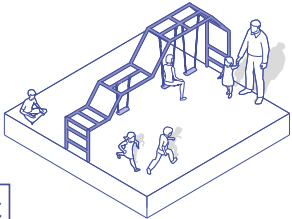
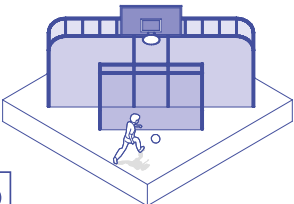
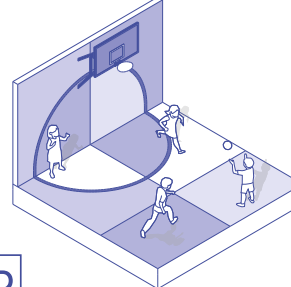
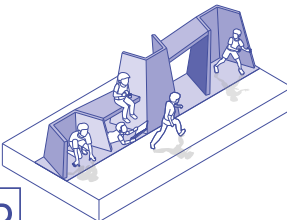
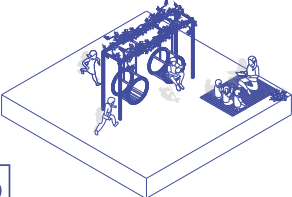
Active zone		Semi-active zone					
1	Physical education and sports	2	Active play	3	Create art	4	Spend time together
1A		2A		3A		4A	
1B		2B		3B		4B	
1C		2C		3C		4C	
1D		2D		3D		4D	

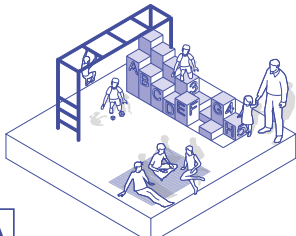
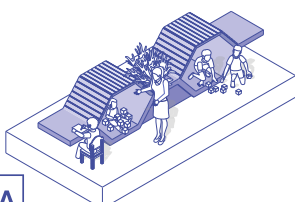
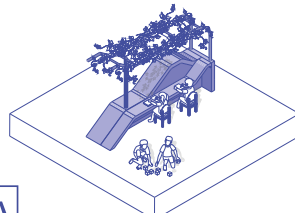
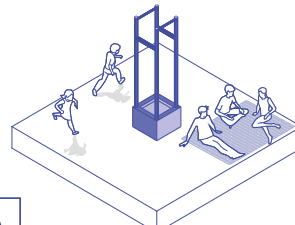
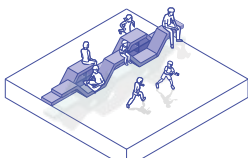
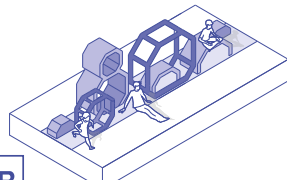
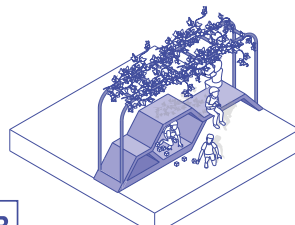
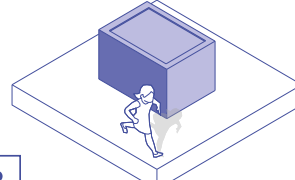
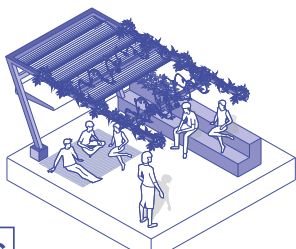
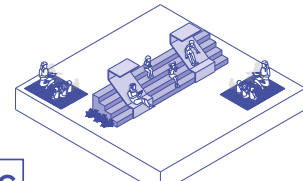
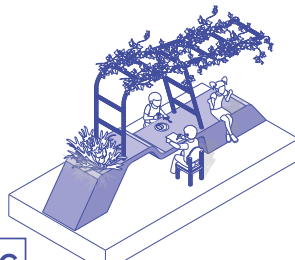
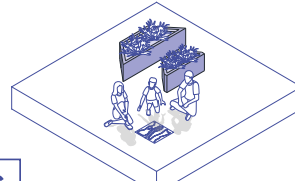
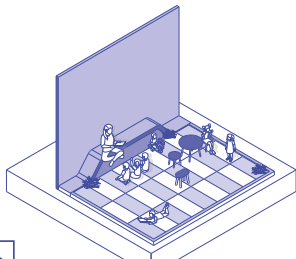
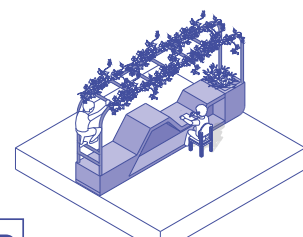
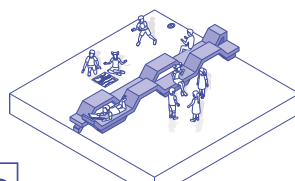
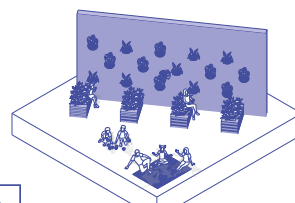
		Quiet zone		Device matrix			
5	Learn	6	Rest	7	Eat	*	Connectors
5A		6A		7A		A	
5B		6B		7B		B	
5C		6C		7C		C	
5D		6D		7D		D	

Physical education and sports

Active zone

01

Physical education and sports

School courtyards are primarily used for physical education classes and sports practice, such as soccer, volleyball, or organized recreational activities. These dynamics encourage physical activity, teamwork, and discipline, while also developing social skills such as cooperation, leadership, and effective communication among students.

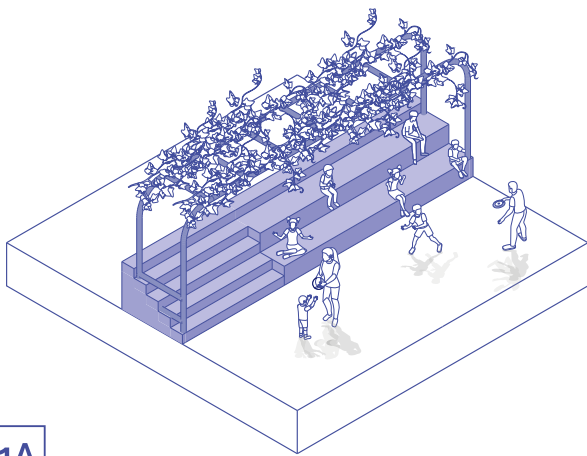

1A

Multifunctional bleachers for physical education

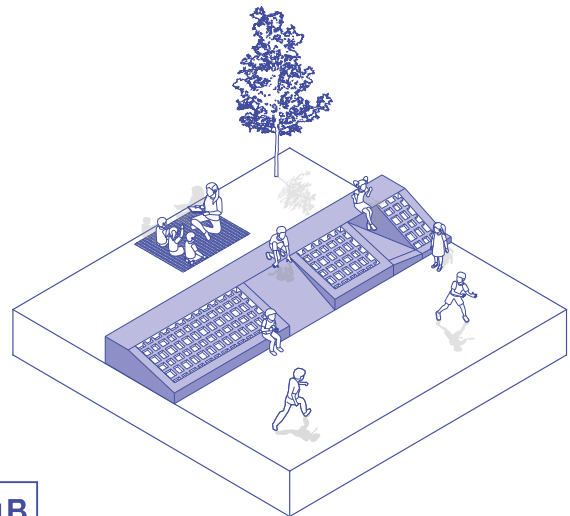

1B

Ramps and climbing structures for sports activity

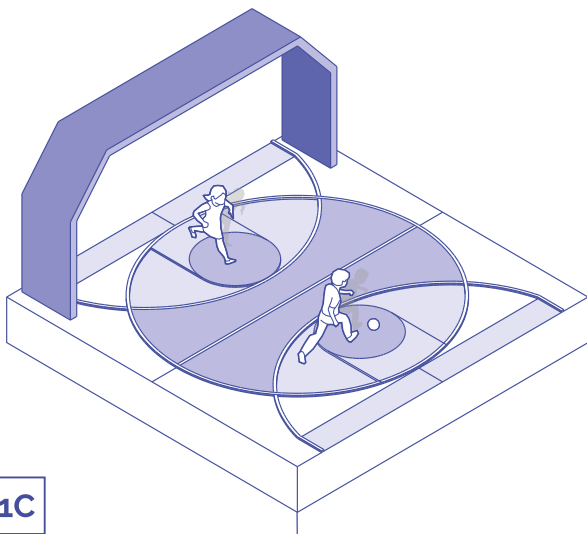

1C

Multifunctional sports arch

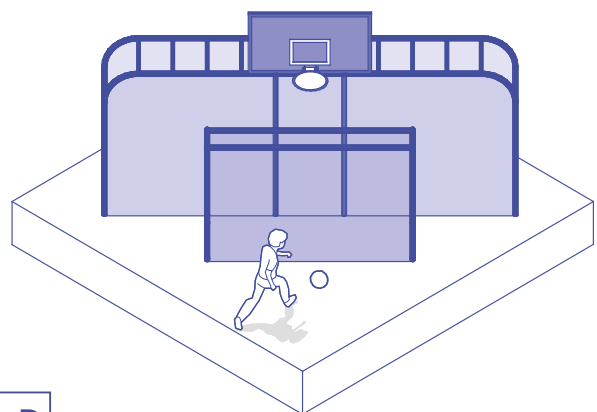

1D

Dual arch for soccer and basketball

Multifunctional bleachers for physical education

Device 1A Description and construction steps

1A

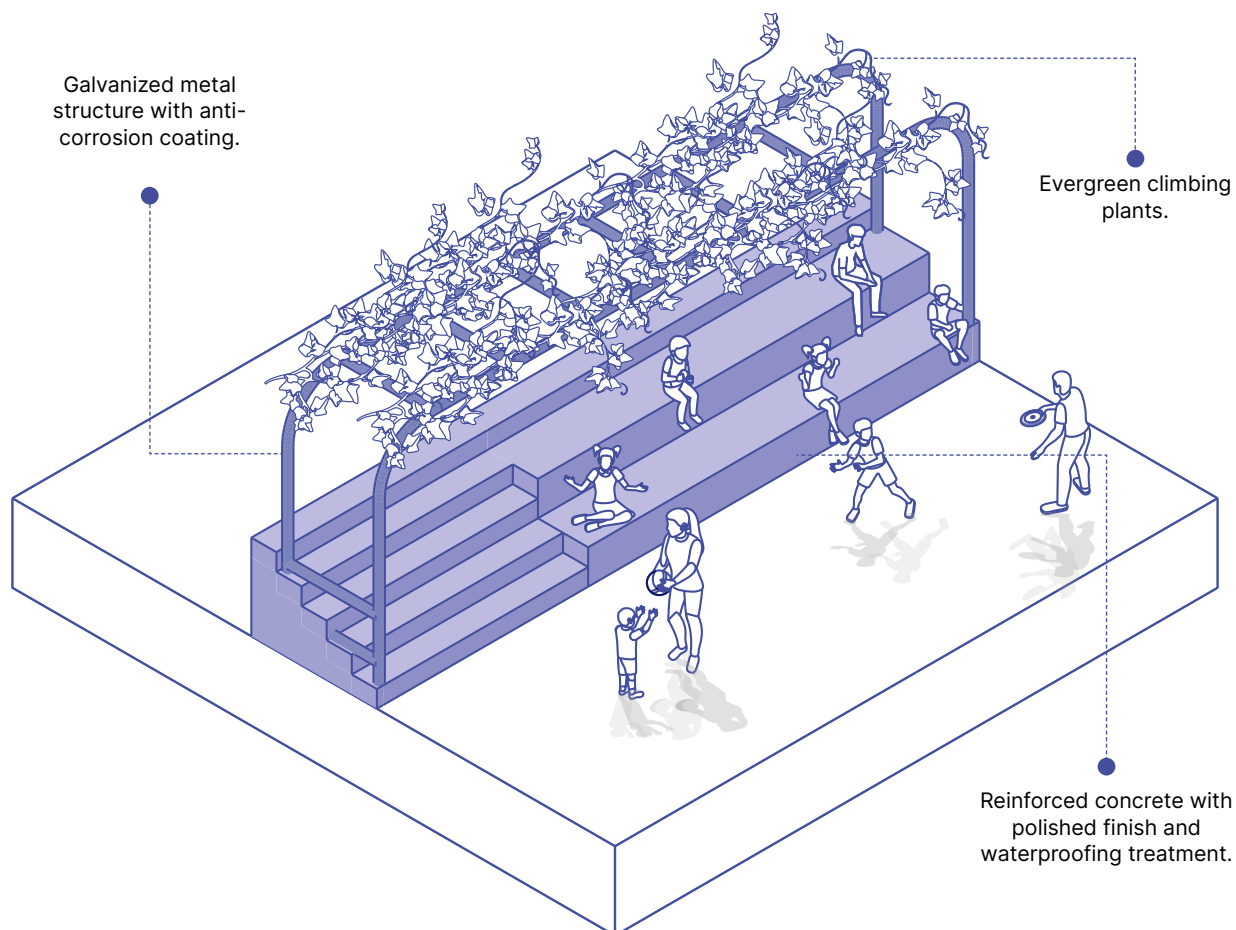

FEATURES	DESCRIPTION
Recommended use	<ul style="list-style-type: none"> • Observation of sports and recreational activities. • Mobility, balance, and coordination exercises. • Meeting and social interaction point.
Users	<ul style="list-style-type: none"> • Education level: preschool, primary, and secondary. • Age group: 4 to 17 years. • School community: students, teachers, and school staff.
Recommended materials	<ul style="list-style-type: none"> • Reinforced concrete with polished finish and waterproofing treatment. • Galvanized metal structure with anti-corrosion coating. • Evergreen climbing plants. • Step finishes to improve safety and grip. • Steel elements for stability and support of dynamic loads.
Suggested dimensions	<ul style="list-style-type: none"> • Maximum height: 1.5 – 2.5 m (depending on the number of steps). • Step depth: 40 – 50 cm. • Width per module: 3 – 6 m (depending on available space).
Maintenance	<ul style="list-style-type: none"> • Regular cleaning of surfaces. • Structural inspection every 6 months. • Repair of worn finishes.
Benefits	<ul style="list-style-type: none"> • Encourages active use of school space. • Promotes physical activity at different intensity levels. • Facilitates social integration and collaborative learning.

Device 1A **Multifunctional bleachers for physical education****1A**

This device is designed to serve as a versatile space within the school courtyard. In addition to its traditional function as a viewing area for sports events and school activities, it allows mobility, stretching, and strengthening exercises during physical education classes.

Its structure may include steps of different heights, handrails, and rest areas, promoting active use of the space and encouraging interaction among students.

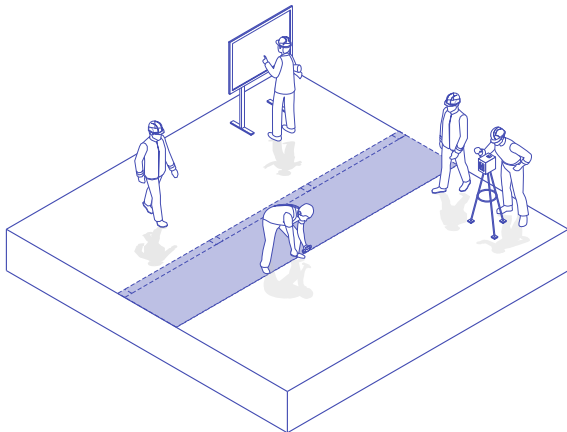
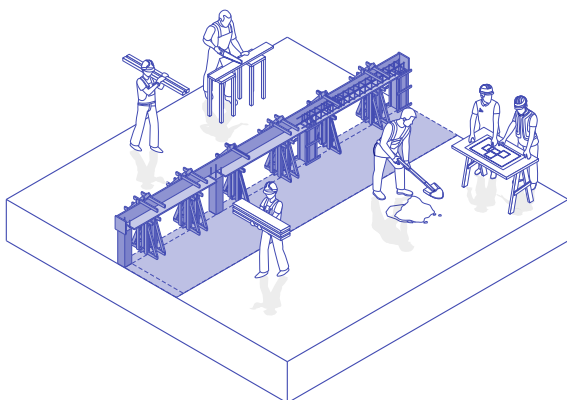
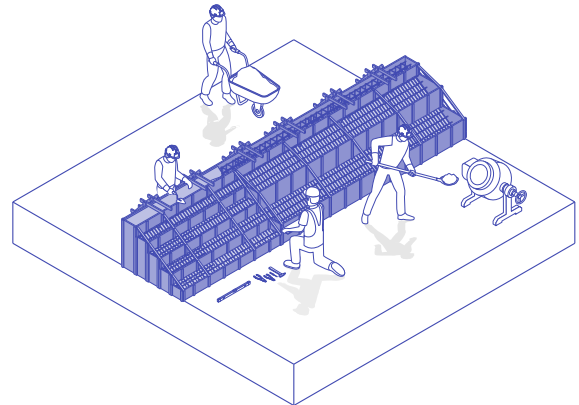
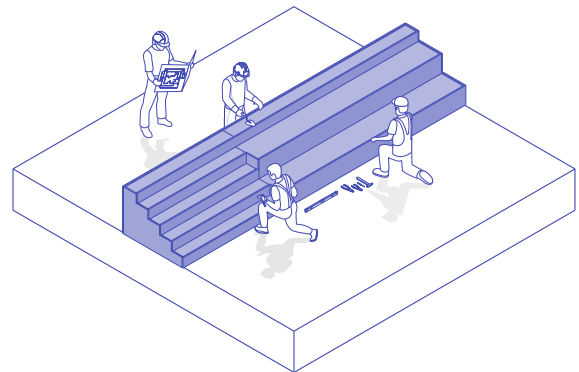
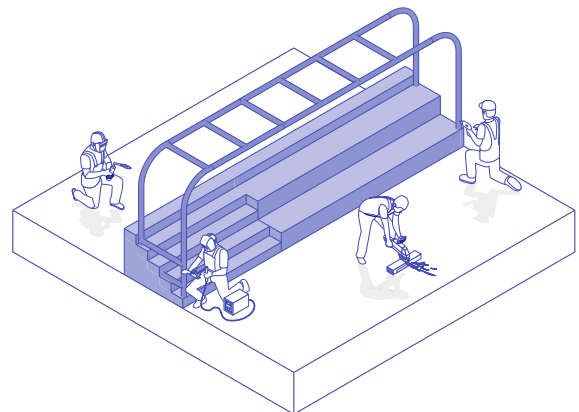
Step 1. Layout and leveling**Step 2.** Base preparation**Step 3.** Formwork, reinforcement, and concrete pouring**Step 4.** Removal and polishing of the concrete**Step 5.** Installation of the metal structure

Ramps and climbing structures for sports activity

Device 1B Description and construction steps

1B

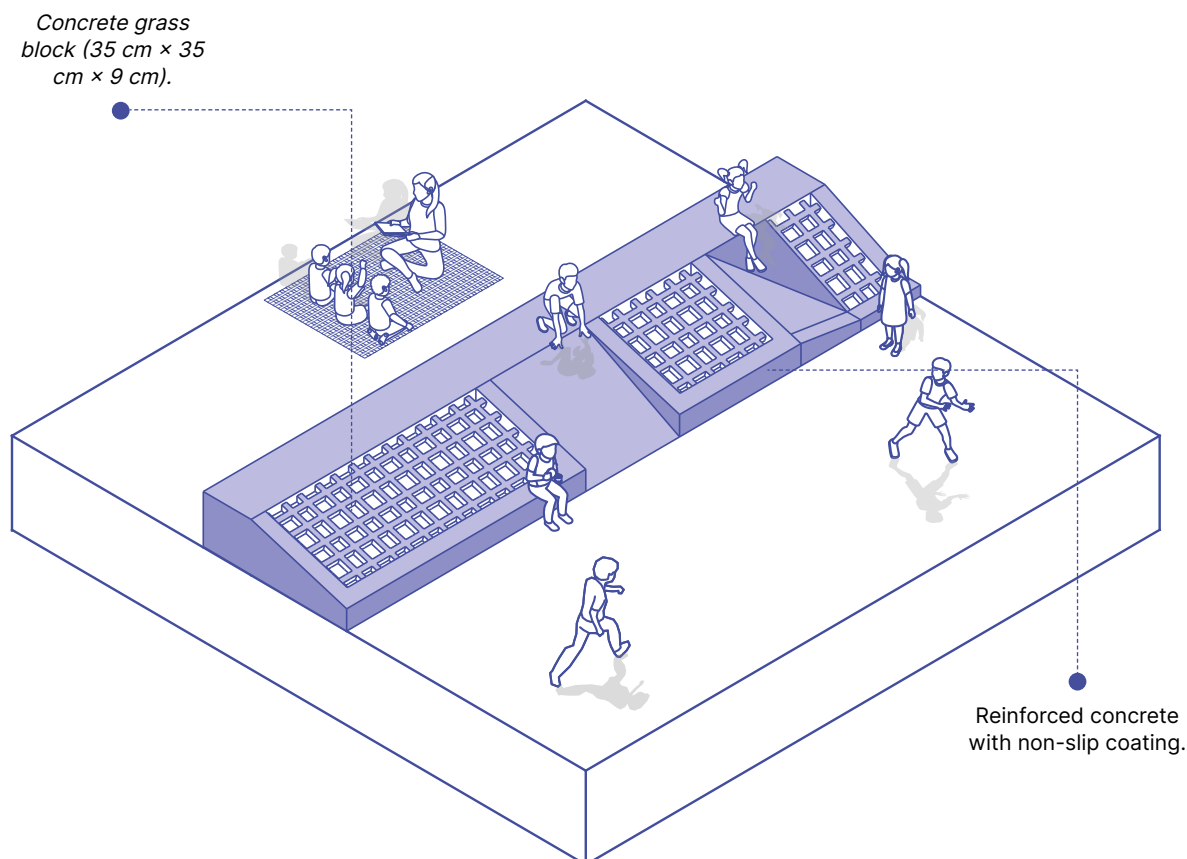

FEATURES	DESCRIPTION
Recommended use	<ul style="list-style-type: none"> • Development of motor skills and coordination. • Physical training and active play. • Physical education activities focused on strength and balance.
Users	<ul style="list-style-type: none"> • Education level: preschool and primary. • Age group: 4 to 12 years. • School community: students and physical education teachers.
Recommended materials	<ul style="list-style-type: none"> • Reinforced concrete with non-slip coating. • Rubber or other impact-absorbing material in impact areas.
Suggested dimensions	<ul style="list-style-type: none"> • Maximum height: 2 – 3 m (depending on required safety level). • Ramp length: 2 – 3 m (depending on slope). • Distance between climbing structures: minimum 1.5 m for safety.
Maintenance	<ul style="list-style-type: none"> • Inspection of welds and joints every 6 months. • Check and adjust tension in ropes and bars. • Cleaning and surface treatment to prevent wear.
Benefits	<ul style="list-style-type: none"> • Improves strength, balance, and coordination. • Encourages active play and teamwork. • Promotes inclusion of different physical ability levels.

Device 1B **Ramps and climbing structures for sports activity****1B**

This set of devices combines inclined ramps with climbing structures designed to stimulate physical activity and motor development. It is ideal for practicing coordination, balance, and strength exercises, incorporating elements such as ropes with different levels of difficulty.

These structures encourage active play, functional training, and student integration in a dynamic and safe environment. Below are the construction steps:

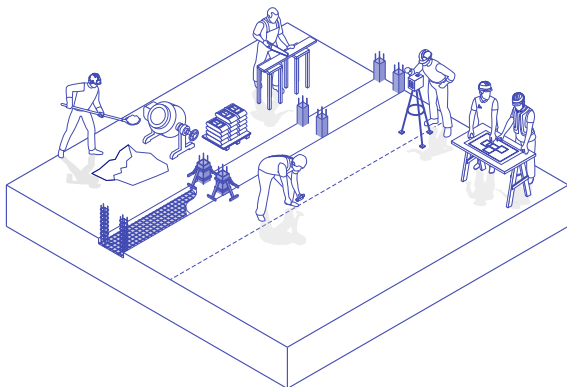
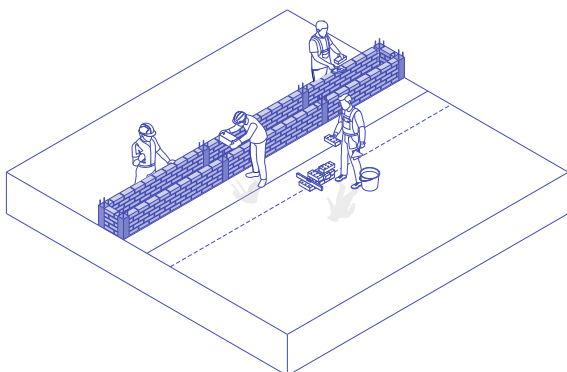
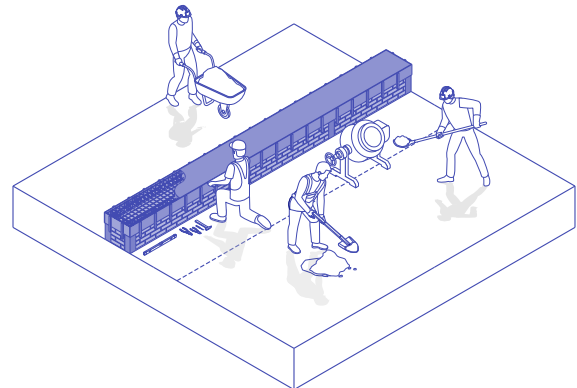
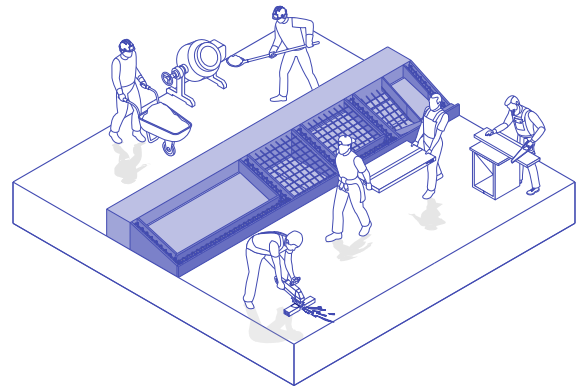
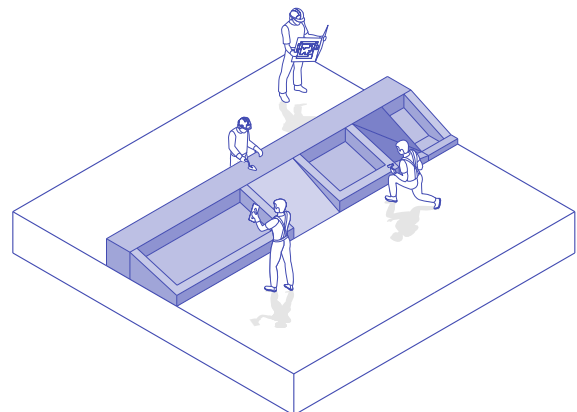
Step 1. Base preparation**Step 2.** Brick wall installation**Step 3.** Formwork and reinforcement**Step 4.** Concrete pouring**Step 5.** Removal and polishing of the concrete

Active play

Active zone

02

Active play

During recess or free moments, students use the courtyard to play in a spontaneous and active way. From traditional games to more modern dynamics, they develop social skills such as cooperation, conflict resolution, and empathy.

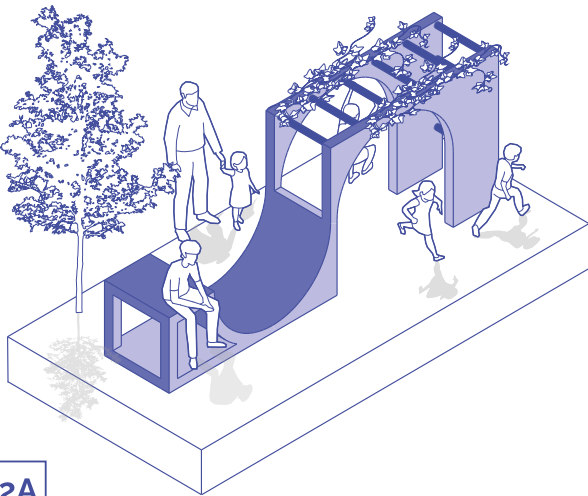

2A

Curved play and gathering structure

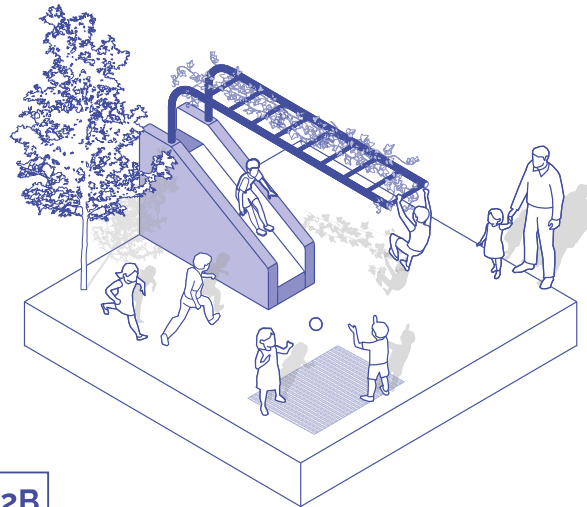

2B

Playful slide with green cover

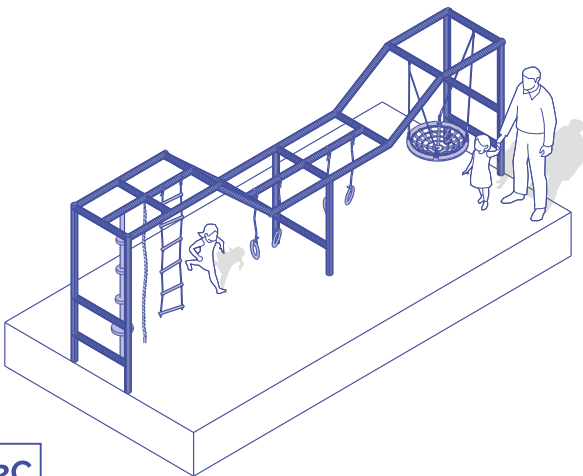

2C

Adventure and climbing

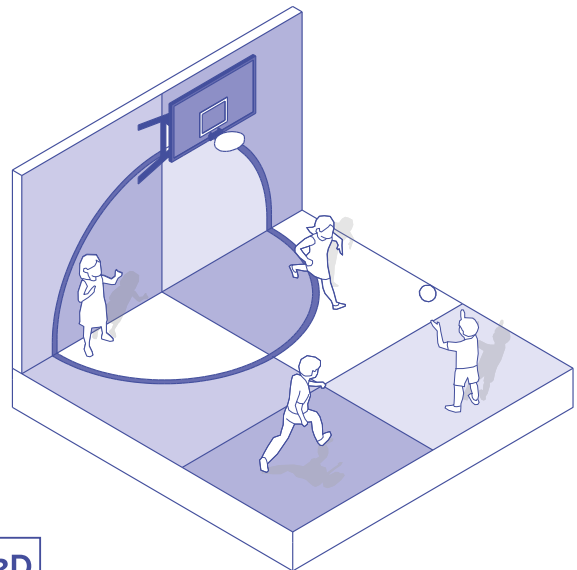

2D

Multifunctional sports wall

Curved play and gathering structure

Device 2A Description and construction steps

2A

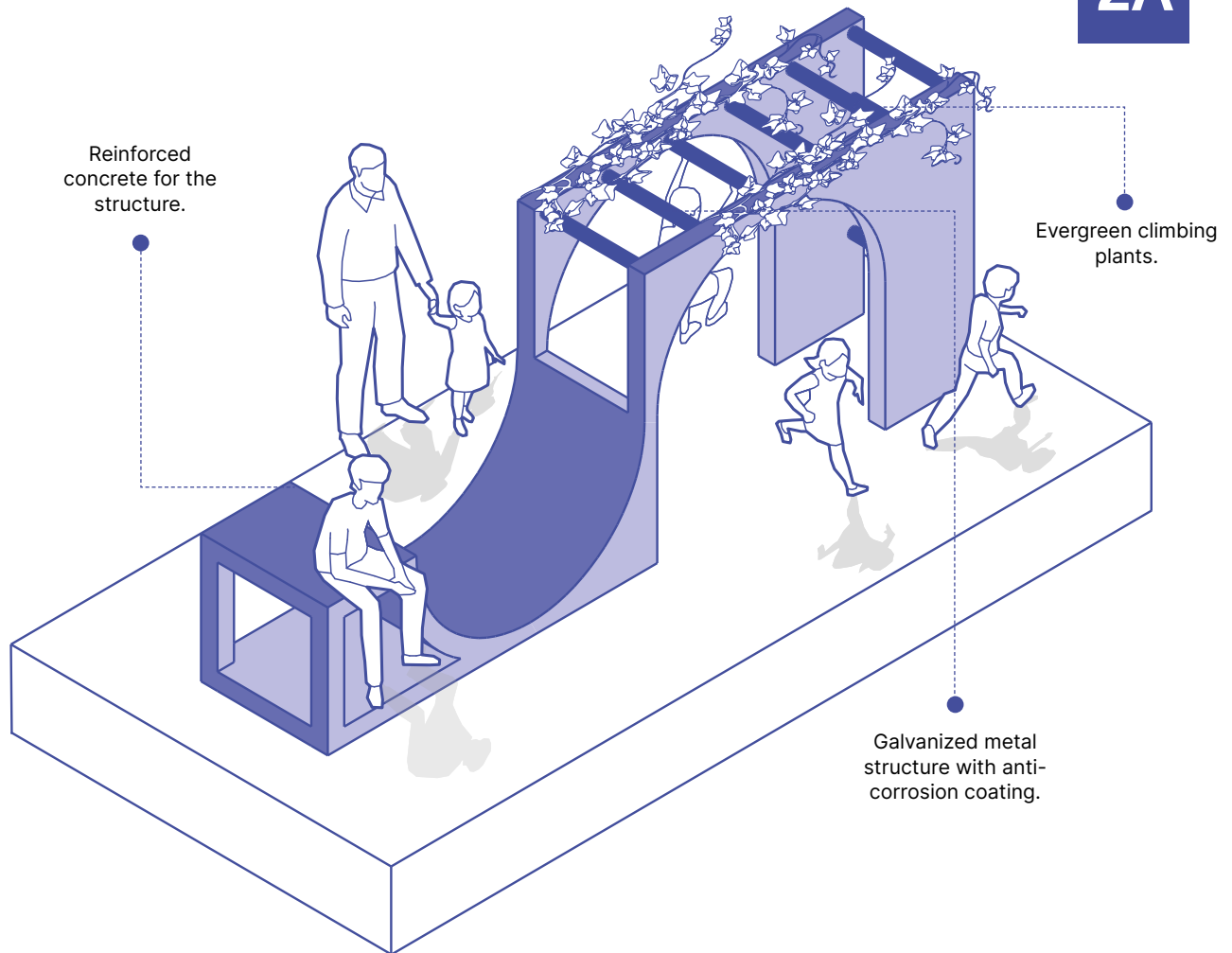

FEATURES	DESCRIPTION
Recommended use	<ul style="list-style-type: none"> • Active play and exploration. • Rest and social interaction. • Learning and outdoor activities.
Users	<ul style="list-style-type: none"> • Education level: primary and secondary. • Age group: 6 to 17 years. • School community: students and teachers.
Recommended materials	<ul style="list-style-type: none"> • Reinforced concrete for the structure. • Surfaces with smooth finishes and rounded edges. • Coatings or finishes that improve safety in contact areas. • Upper metal structure with climbing plants to provide shade.
Suggested dimensions	<ul style="list-style-type: none"> • Maximum height: 2.5 m. • Length: 6 m. • Width: 1 m.
Maintenance	<ul style="list-style-type: none"> • Regular cleaning of surfaces. • Structural inspection every 6 months. • Pruning and maintenance of vegetation.
Benefits	<ul style="list-style-type: none"> • Promotes play and physical activity. • Encourages social interaction and rest. • Improves environmental quality through shade and vegetation.

Device 2A **Curved play and gathering structure**

2A

This device integrates play, rest, and social interaction into a single element. Its curved structure allows climbing, sliding, and exploration, promoting movement and coordination development.

It combines rest areas with benches and shaded spaces generated by the vegetation cover. In addition, it incorporates tables and desks, encouraging social interaction and outdoor learning in a playful and dynamic environment. Below are the construction steps:

Step 1. Layout and leveling

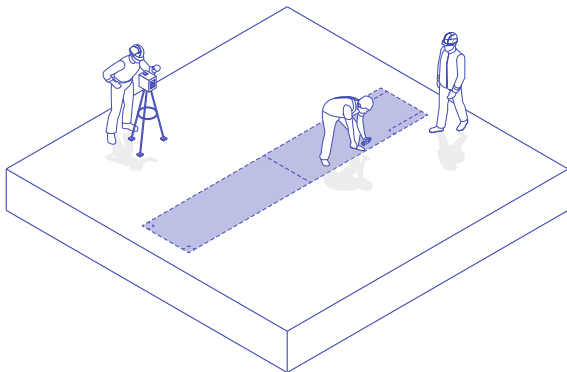

Step 2. Formwork, reinforcement, and lower concrete pouring

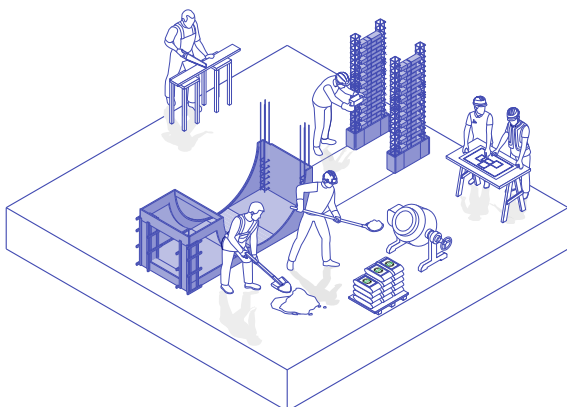

Step 3. Formwork, reinforcement, and upper concrete pouring

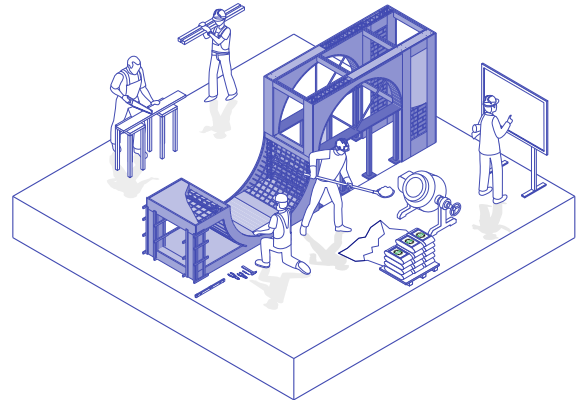

Step 4. Removal and polishing of the concrete

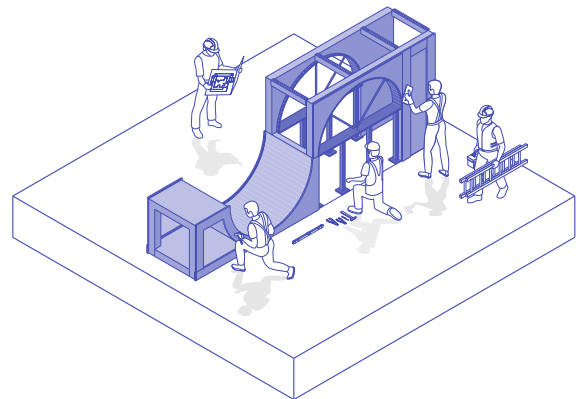

Step 5. Installation of the metal structure

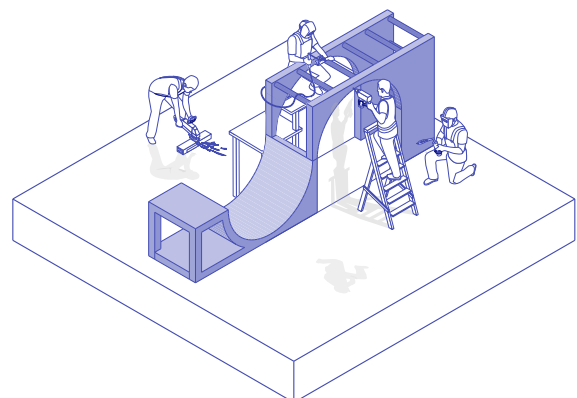

Playful Slide with Green Canopy

Device 2B Description and construction steps

2B

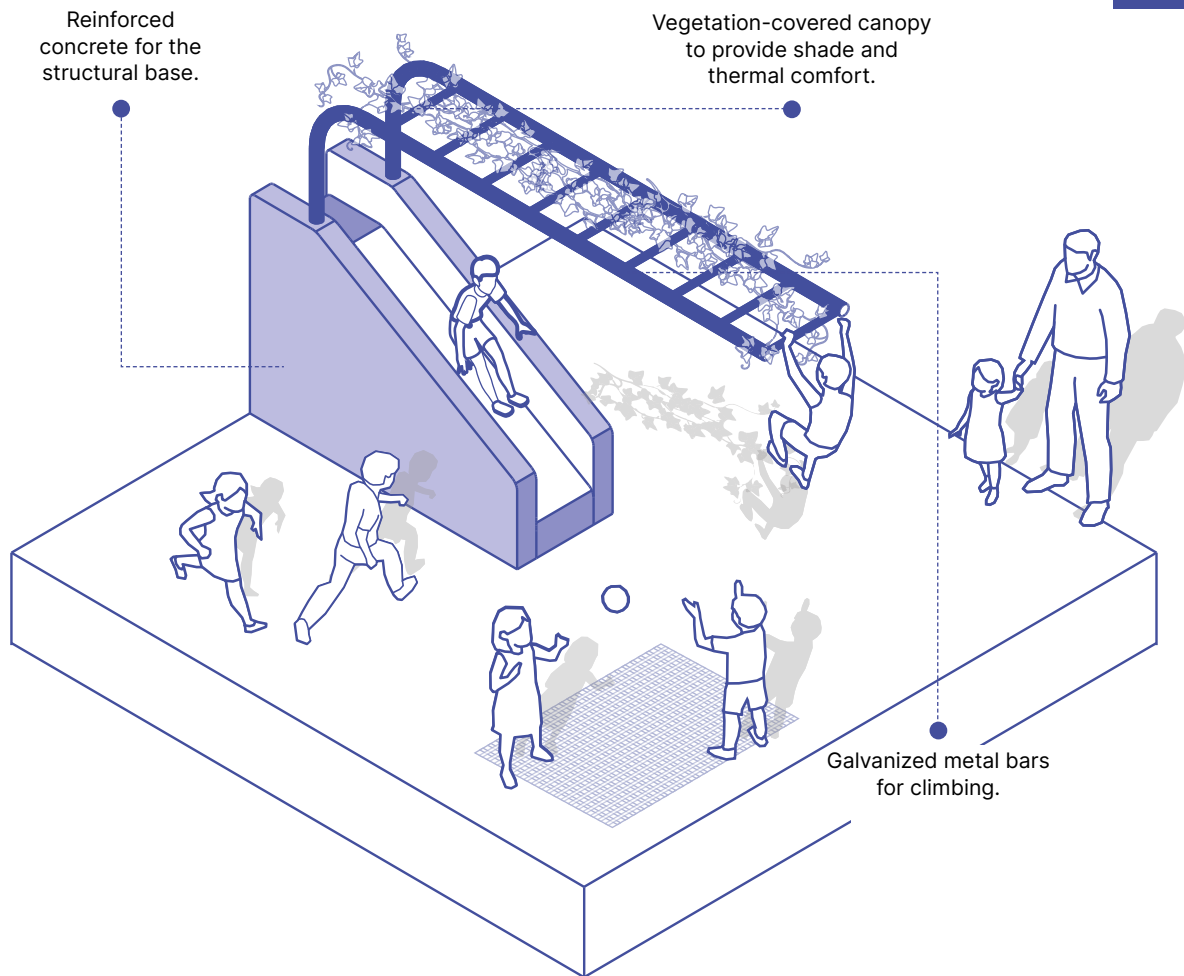

FEATURES	DESCRIPTION
Recommended Use	<ul style="list-style-type: none"> • Active play and exploration • Development of motor skills and coordination • Physical education and recreational activities
Users	<ul style="list-style-type: none"> • Educational level: Primary • Age group: 6 to 12 years old • Educational community: Students and teachers
Recommended Materials	<ul style="list-style-type: none"> • Reinforced concrete for the structural base • Sliding surface made of stainless steel or high-resistance polyethylene • Galvanized metal bars for climbing • Vegetation-covered canopy to provide shade and thermal comfort
Suggested Dimensions	<ul style="list-style-type: none"> • Maximum height: 2.5 – 3 m • Length: 3 – 4 m • Width: 1 m
Maintenance	<ul style="list-style-type: none"> • Regular cleaning of surfaces and structure • Stability and safety inspection every 6 months • Pruning and maintenance of vegetation
Benefits	<ul style="list-style-type: none"> • Improves coordination and balance • Encourages free play and physical activity • Promotes socialization and creativity among students

This device encourages physical activity, play and social interaction through a combination of climbing, sliding and suspension. It incorporates a ramp with a slide, climbing bars, and an overhead structure with vegetation that provides shade.

Designed to stimulate motor coordination, balance and creativity, this module enables multiple forms of exploration, promoting free play and learning through movement within the schoolyard. Below are the construction steps:

Step 1. Layout and leveling

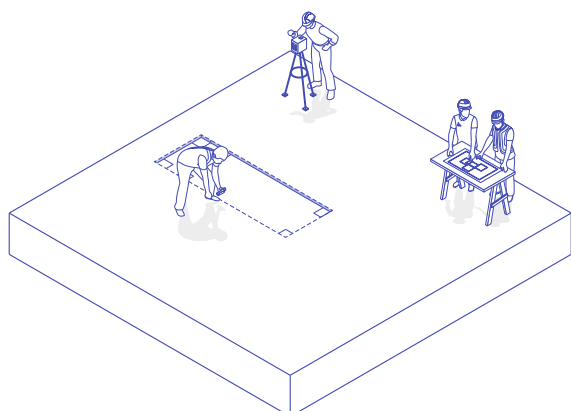

Step 2. Base preparation

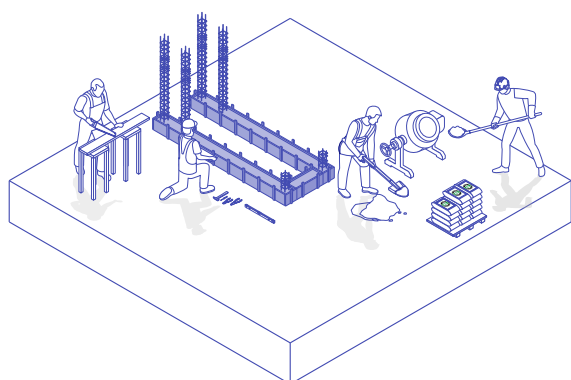

Step 3. Brick wall installation

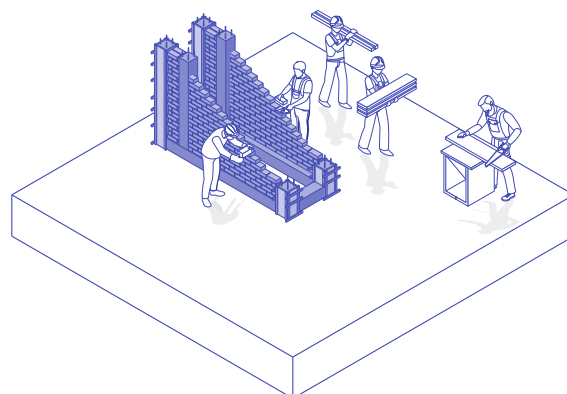

Step 4. Formwork, reinforcement and concrete pouring

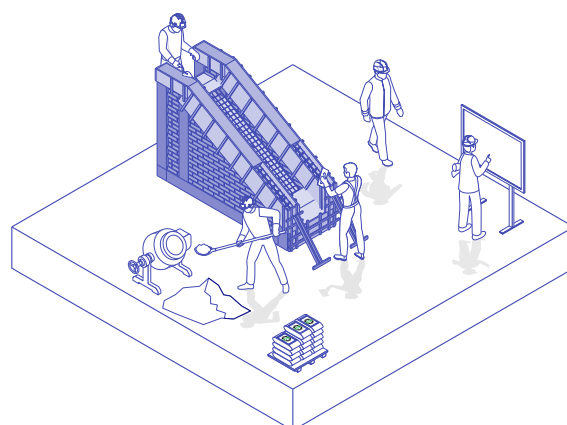

Step 5. Formwork removal, concrete finishing and installation of the metal structure

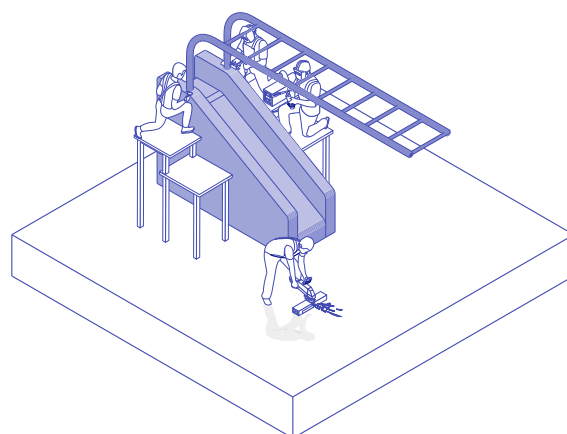

Create art

Semi-active zone

03

Create art

In some cases, students use courtyards to engage in artistic activities such as painting murals, creating crafts, or preparing cultural performances. These moments promote creativity and personal expression, while also strengthening social skills such as collaboration, self-esteem, and respect for others' ideas.

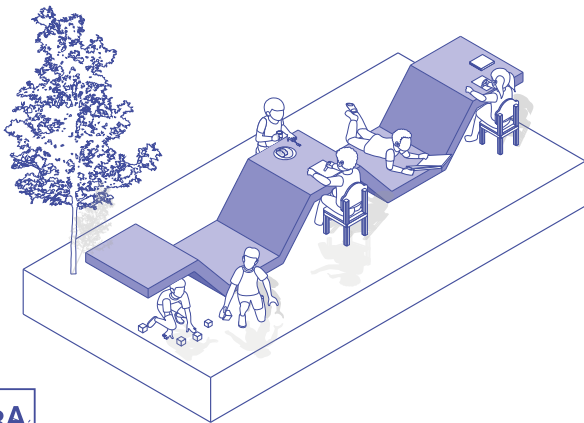

3A

Modular creative platform

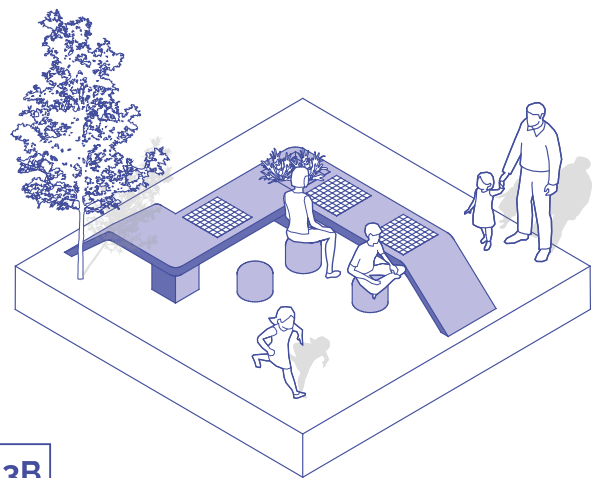

3B

Creation and chess table

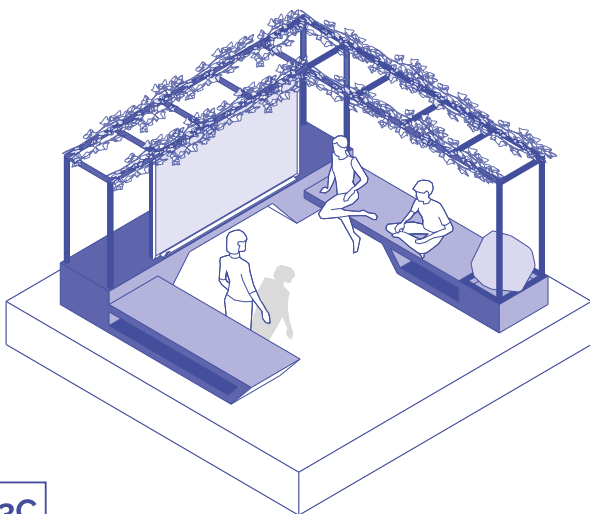

3C

Creative agora

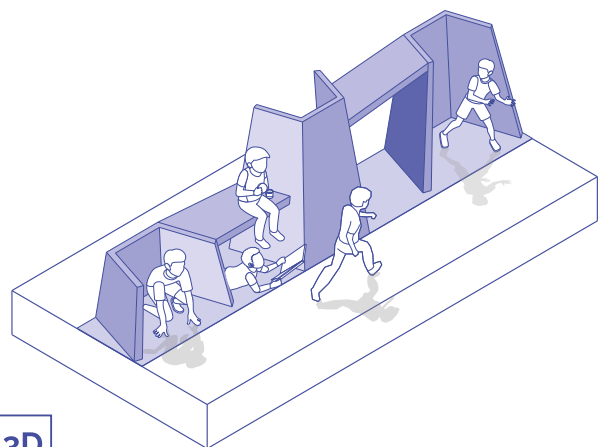

3D

Interactive wall for creation and display

Modular creative platform

Device 3A Description and construction steps

3A

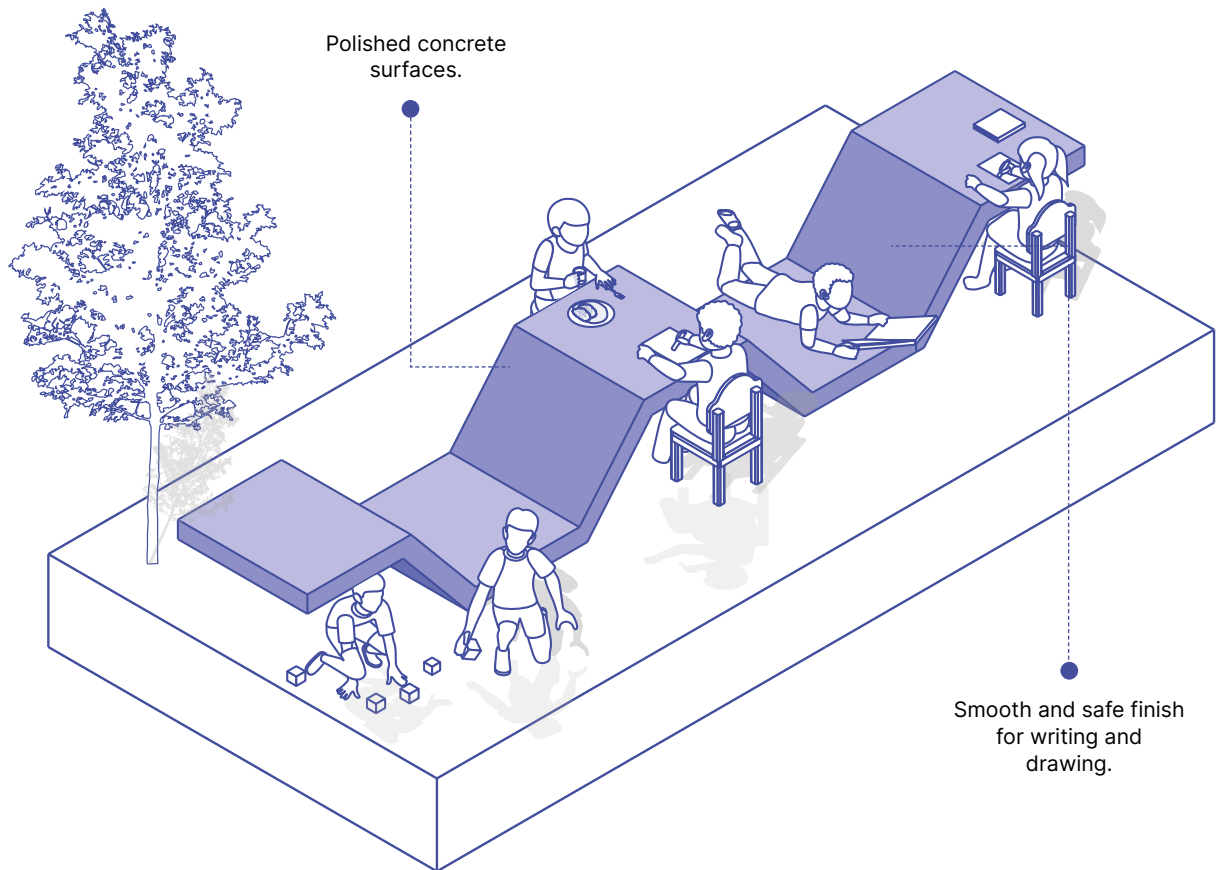

FEATURES	DESCRIPTION
Recommended use	<ul style="list-style-type: none"> • Artistic creation and sensory exploration. • Collaborative work and experimentation. • Learning and social interaction space.
Users	<ul style="list-style-type: none"> • Education level: primary and secondary. • Age group: 6 to 17 years. • School community: students and teachers.
Recommended materials	<ul style="list-style-type: none"> • Polished concrete surfaces. • Smooth and safe finish for writing and drawing. • Reinforced metal structure for stability.
Suggested dimensions	<ul style="list-style-type: none"> • Length: 6 m. • Width: 1 m. • Variable height: 0.5 – 1.5 m.
Maintenance	<ul style="list-style-type: none"> • Regular cleaning of surfaces. • Structural inspection every 6 months. • Protection against weather conditions to ensure durability.
Benefits	<ul style="list-style-type: none"> • Encourages creativity and artistic exploration. • Allows different forms of work and expression. • Creates an inclusive and dynamic learning environment.

Device 3A **Modular creative platform****3A**

This device provides a versatile space for artistic exploration and creativity. Its design allows for surfaces inclined at different positions, promoting comfort and experimentation.

It integrates work areas for drawing, sculpture, and writing, as well as spaces for social interaction and collaborative learning. It is ideal for developing creative skills in a dynamic and flexible environment within the school courtyard. Below are the construction steps:

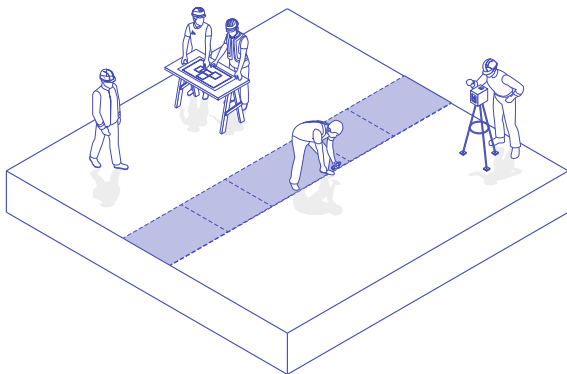
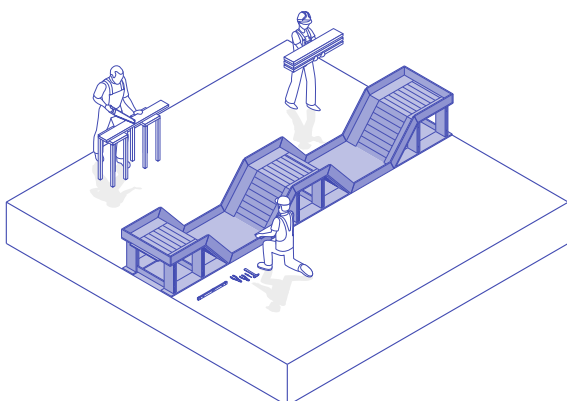
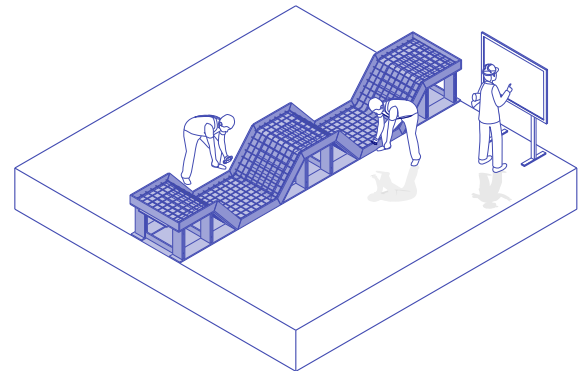
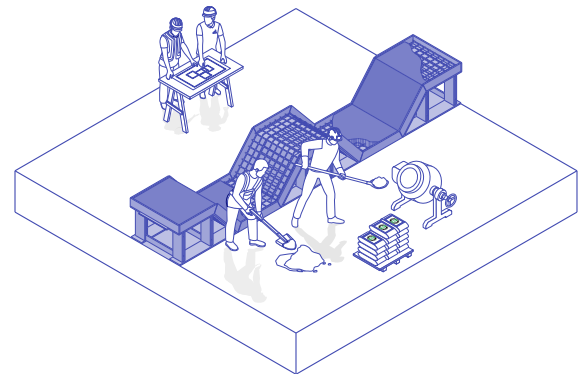
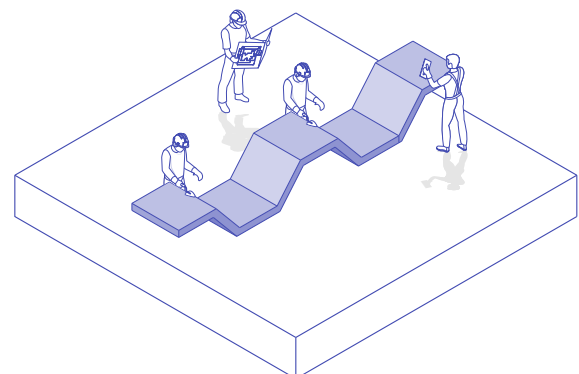
Step 1. Layout and leveling**Step 2.** Base preparation**Step 3.** Formwork and reinforcement**Step 4.** Concrete pouring**Step 5.** Removal and polishing of the concrete

Creation and chess table

Device 3B Description and construction steps

3B

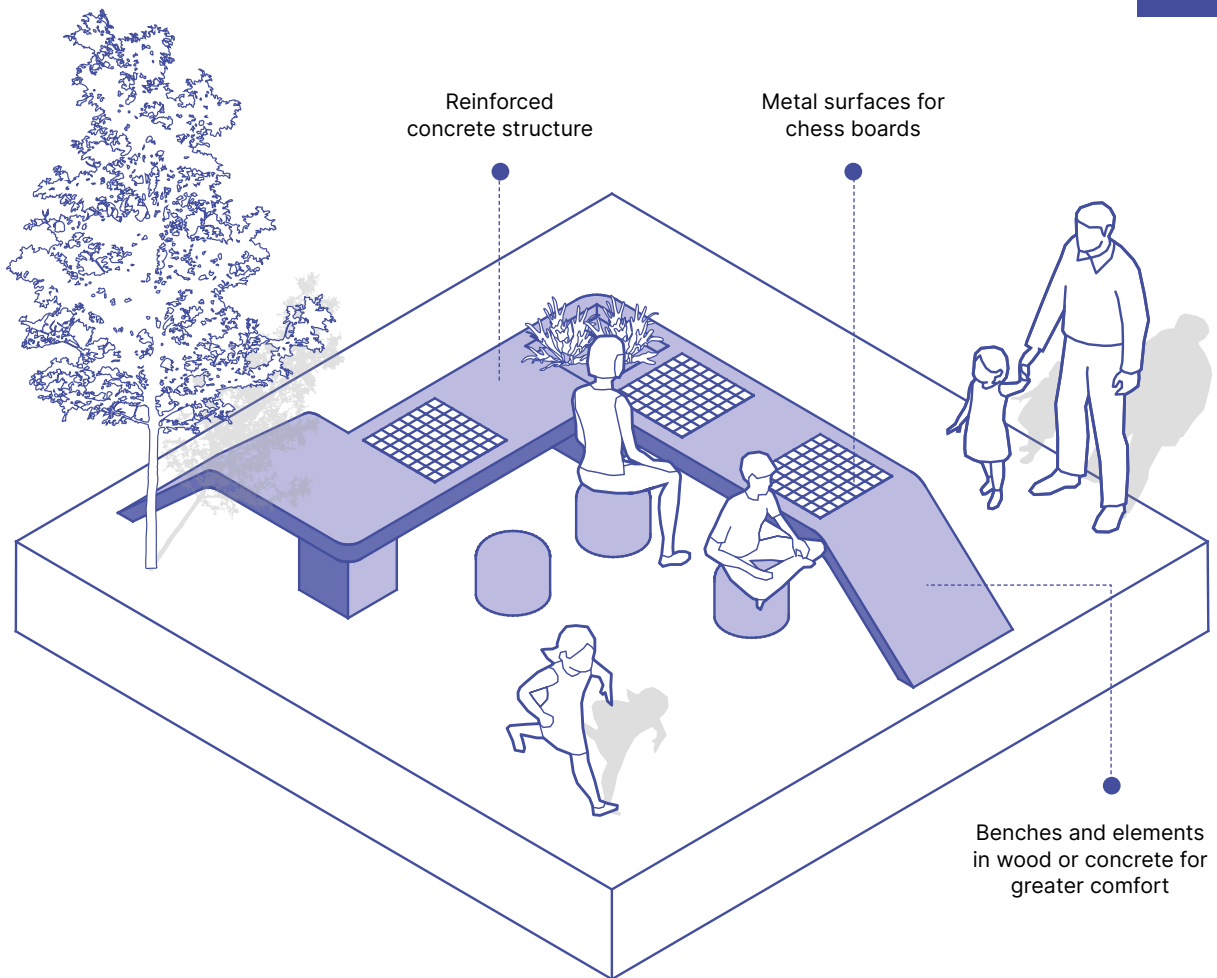

FEATURES	DESCRIPTION
Recommended use	<ul style="list-style-type: none"> • Chess play and strategic activities. • Artistic creation and collaborative learning. • Social interaction and recreation space.
Users	<ul style="list-style-type: none"> • Education level: primary and secondary. • Age group: 6 to 17 years. • School community: students and teachers.
Recommended materials	<ul style="list-style-type: none"> • Reinforced concrete structure. • Metal surfaces for chess boards. • Benches and elements in wood or concrete for greater comfort.
Suggested dimensions	<ul style="list-style-type: none"> • Length: 3 – 4 m. • Width: 1 m. • Variable height: 0.9 m.
Maintenance	<ul style="list-style-type: none"> • Regular cleaning of surfaces and boards. • Structural inspection every 6 months. • Protection against weather conditions to ensure durability.
Benefits	<ul style="list-style-type: none"> • Encourages logical and strategic thinking. • Promotes creativity and collaborative learning. • Creates an inclusive space for play and recreation.

Device 3B **Creation and chess table****3B**

This device combines spaces for creativity with surfaces designed for chess play. Its reinforced concrete structure ensures durability, while its multi-level design allows for versatile use.

It is ideal for encouraging strategic thinking, social interaction, and learning through play and artistic expression. Its integration in the school courtyard promotes cognitive development and coexistence among students. Below are the construction steps:

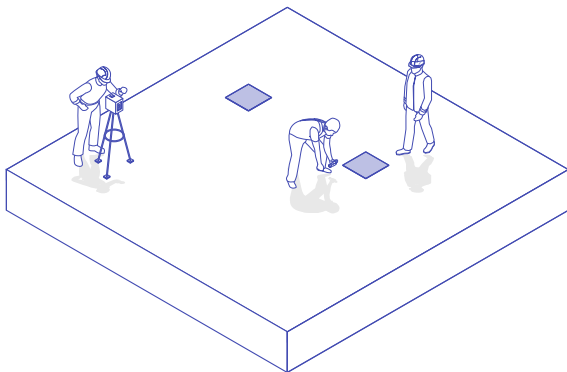
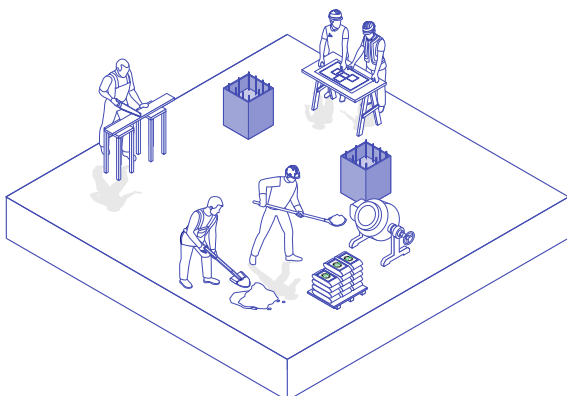
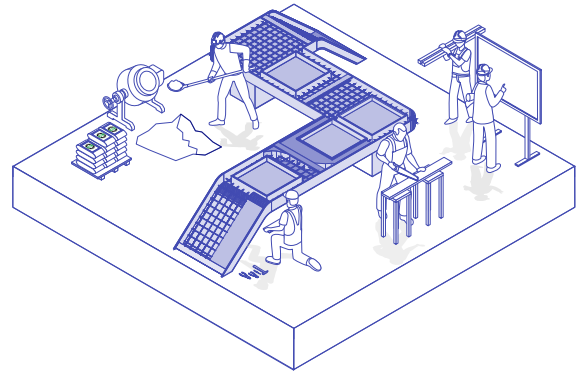
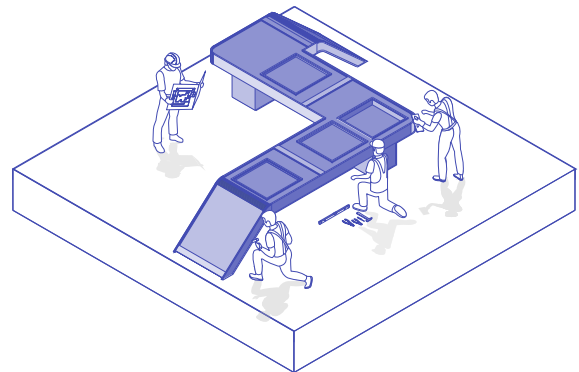
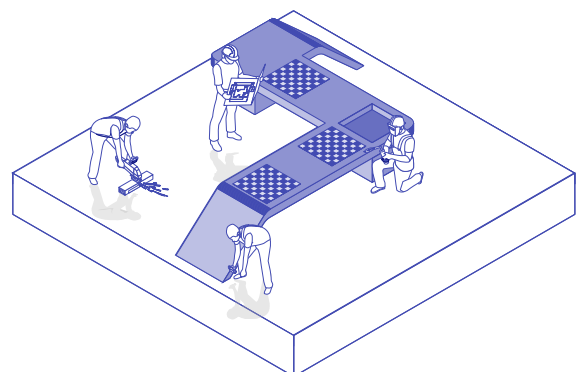
Step 1. Layout and leveling**Step 2.** Base preparation**Step 3.** Formwork, reinforcement, and concrete pouring**Step 4.** Removal and polishing of the concrete**Step 5.** Installation of the chess boards

Spend time together

Semi-active zone

04

Spend time together

The courtyard also serves as a social space where students interact, talk, and strengthen their bonds with classmates. It is a meeting place that fosters a sense of community. In addition, it helps develop social skills such as empathy, active listening, and conflict resolution.

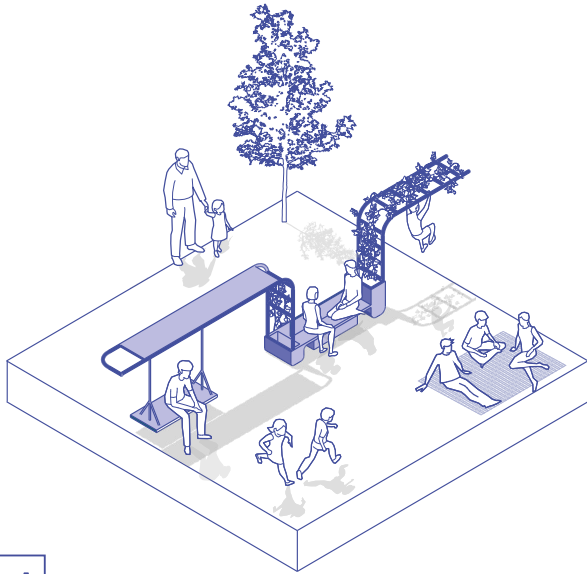

4A

Playful meeting space

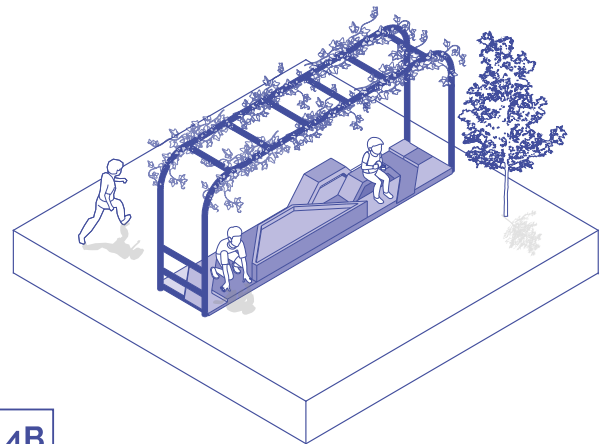

4B

Meeting and rest pergola

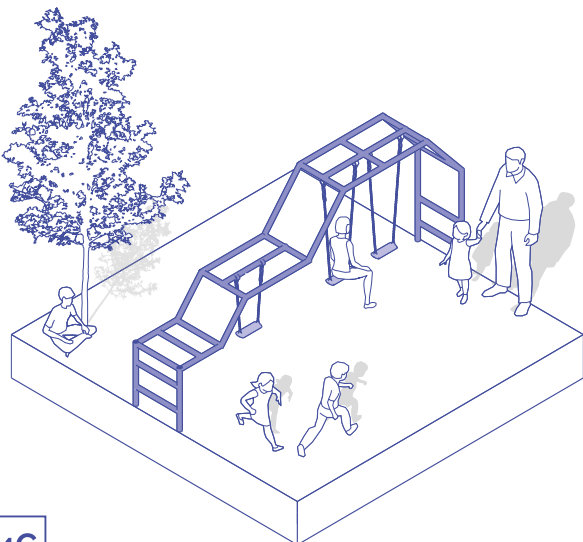

4C

Meeting and play structure

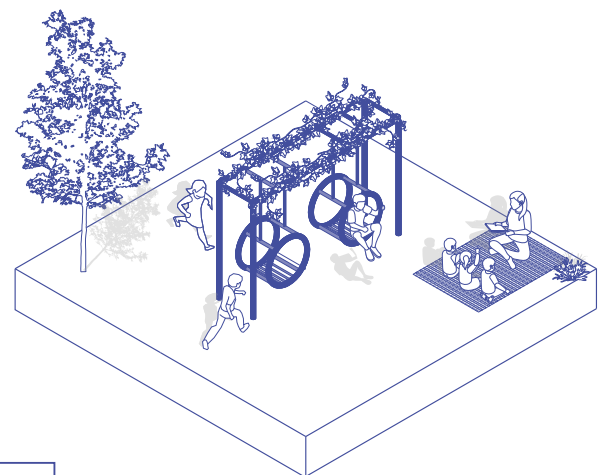

4D

Play and rest structure

Playful meeting space

Device 4A Description and construction steps

4A

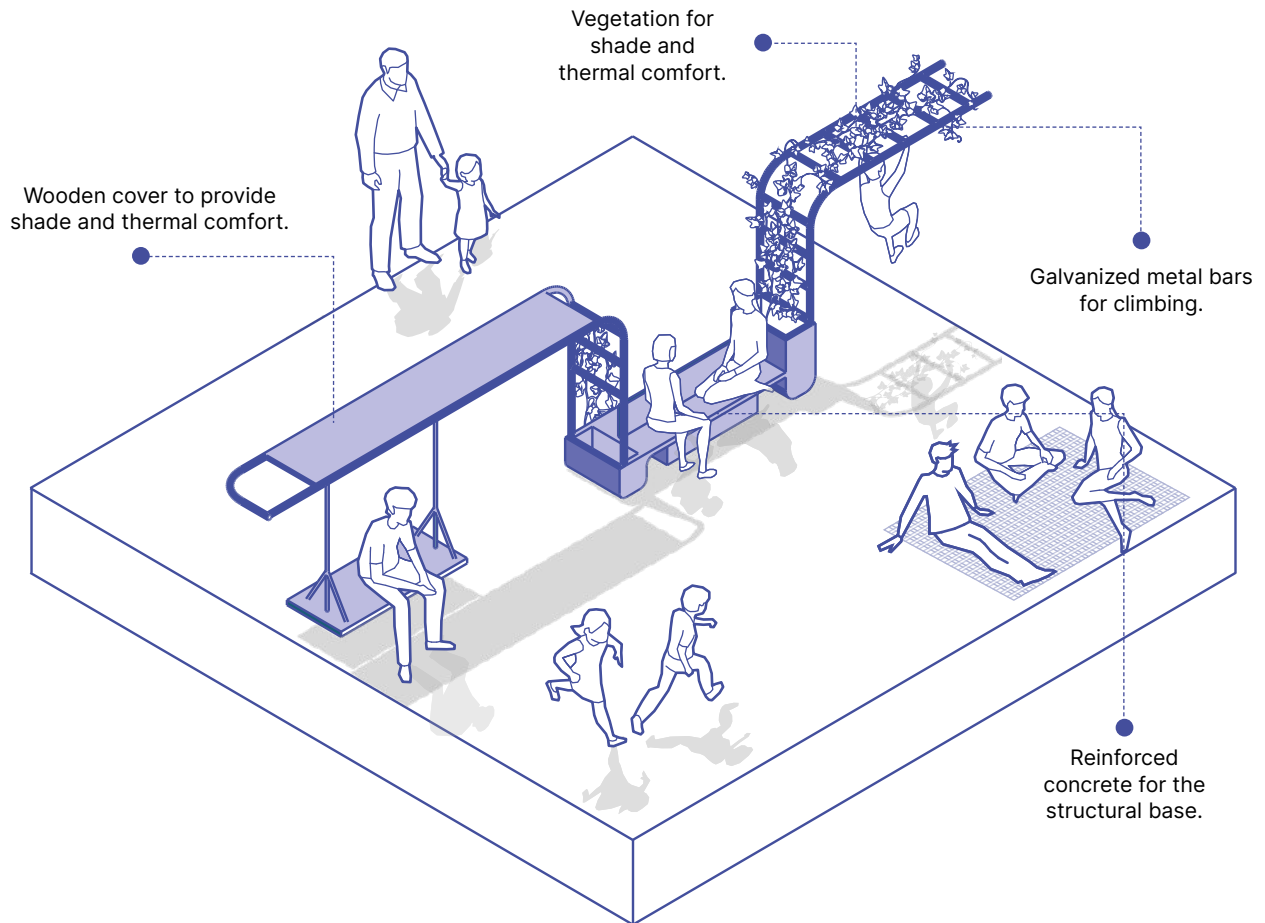

FEATURES	DESCRIPTION
Recommended use	<ul style="list-style-type: none"> • Social interaction and recreation space. • Rest and gathering area. • Active play and relaxation.
Users	<ul style="list-style-type: none"> • Education level: primary and secondary. • Age group: 6 to 17 years. • School community: students and teachers.
Recommended materials	<ul style="list-style-type: none"> • Reinforced concrete for the structure. • Metal elements for swings and pergola. • Vegetation for shade and thermal comfort.
Suggested dimensions	<ul style="list-style-type: none"> • Length: 6 m. • Width: 1 m. • Height: 2.5 – 3 m.
Maintenance	<ul style="list-style-type: none"> • Regular cleaning of surfaces and furniture. • Structural inspection every 6 months. • Pruning and maintenance of vegetation.
Benefits	<ul style="list-style-type: none"> • Encourages coexistence and rest. • Provides shade and comfort. • Integrates play and relaxation elements.

Device 4A **Playful meeting space**

4A

This device combines rest and play areas into a single space. Its concrete and metal structure integrates an elevated bench with swings and a pergola with vegetation, providing shade and comfort.

Designed for social interaction, rest, and recreation, it promotes coexistence in a playful and relaxed environment. Below are the construction steps:

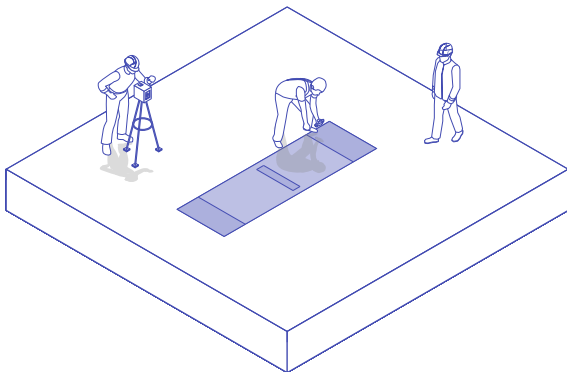
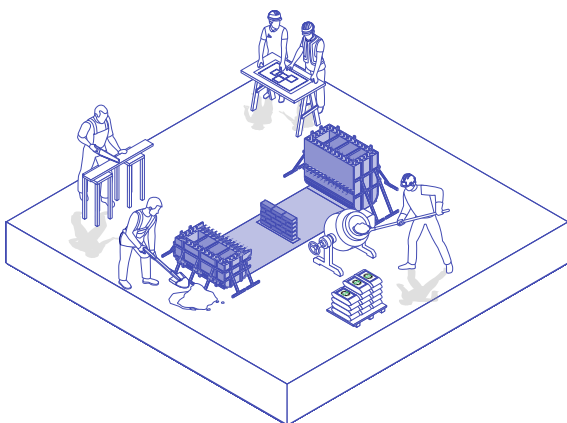
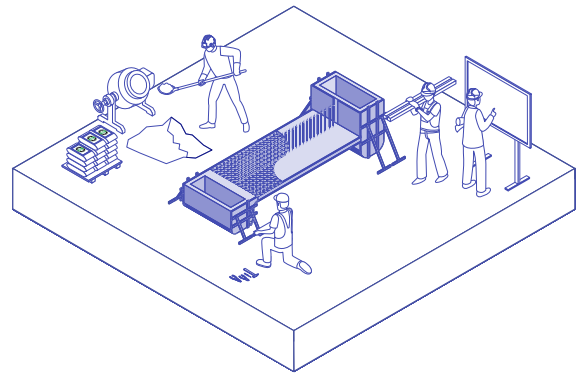
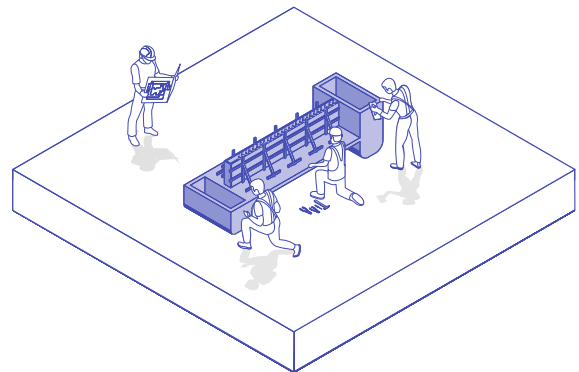
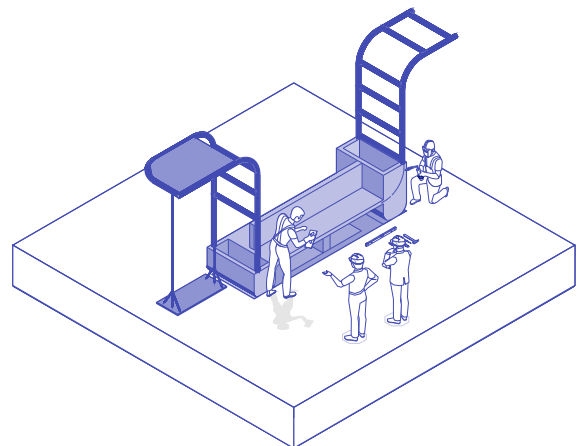
Step 1. Layout and leveling**Step 2.** Base preparation**Step 3.** Formwork, reinforcement, and concrete pouring**Step 4.** Removal and polishing of the concrete**Step 5.** Installation of the metal structure

Meeting and rest pergola

Device 4B Description and construction steps

4B

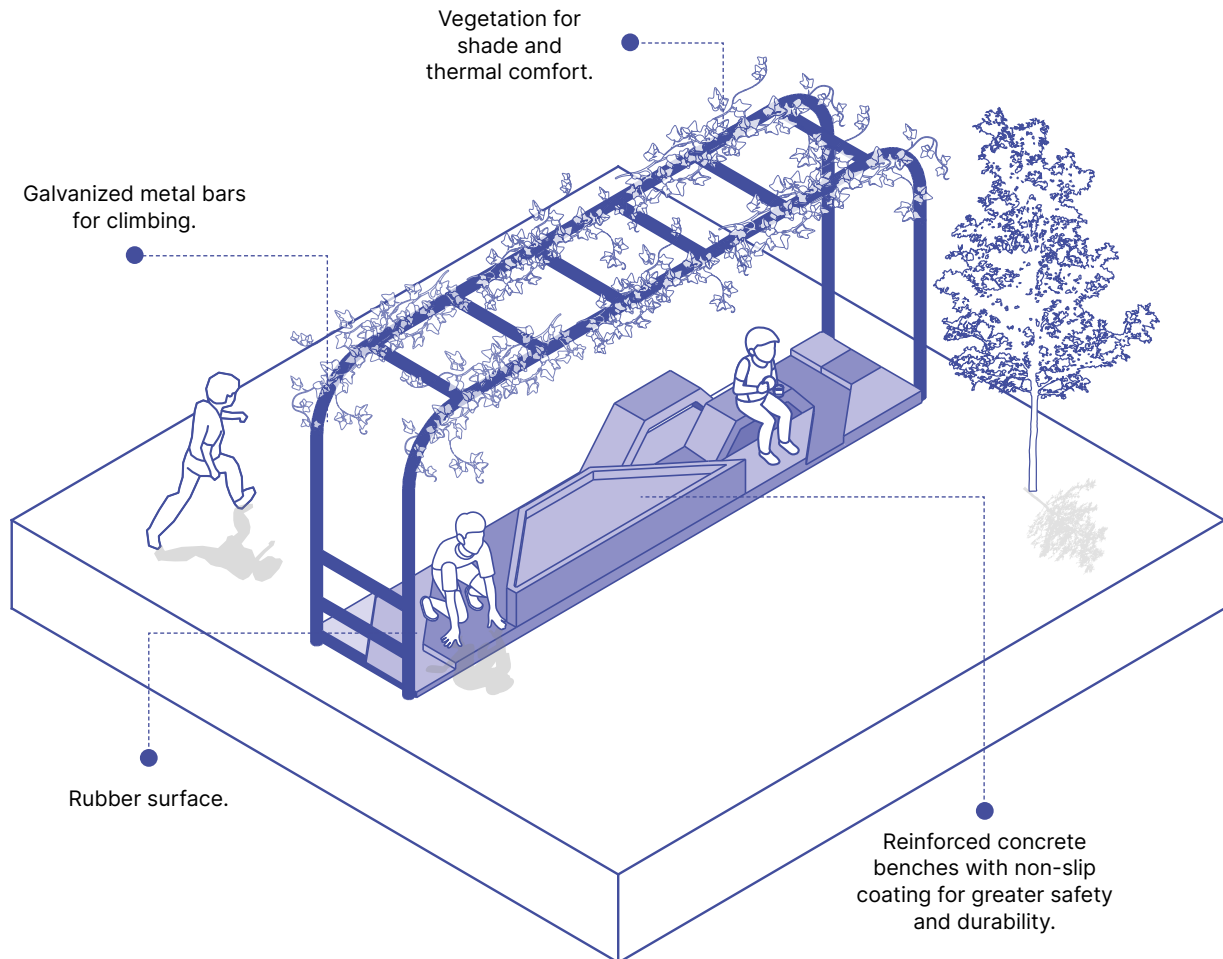

FEATURES	DESCRIPTION
Recommended use	<ul style="list-style-type: none"> • Rest and relaxation area. • Conversation and gathering space. • Recreational activities in shaded areas.
Users	<ul style="list-style-type: none"> • Education level: preschool, primary, and secondary. • Age group: 4 to 17 years. • School community: students and teachers.
Recommended materials	<ul style="list-style-type: none"> • Concrete structure for benches and support. • Galvanized metal elements for the pergola. • Climbing vegetation for natural shade.
Suggested dimensions	<ul style="list-style-type: none"> • Length: 3 – 6 m. • Width: 1 m. • Height: 2.5 – 3 m.
Maintenance	<ul style="list-style-type: none"> • Periodic cleaning of benches and structures. • Pergola inspection every 6 months. • Care and pruning of vegetation.
Benefits	<ul style="list-style-type: none"> • Provides a protected space for social interaction. • Encourages rest and emotional well-being. • Improves environmental quality with integrated vegetation.

Device 4B Meeting and rest pergola

4B

This device is designed as a refuge within the school courtyard, combining modular benches with a pergola covered with vegetation. Its concrete and metal structure provides durability and stability.

It is ideal for rest, conversation, and recreation, creating a welcoming environment for social interaction and relaxation, while protecting users from weather conditions. Below are the construction steps:

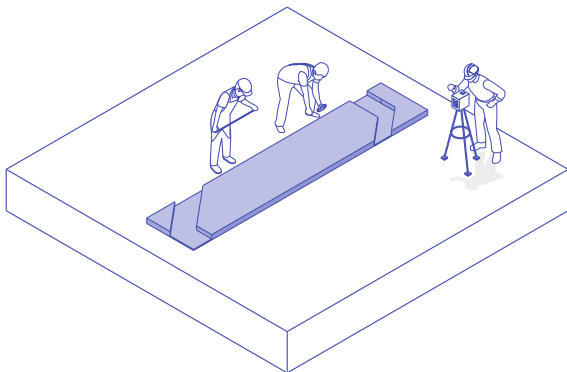
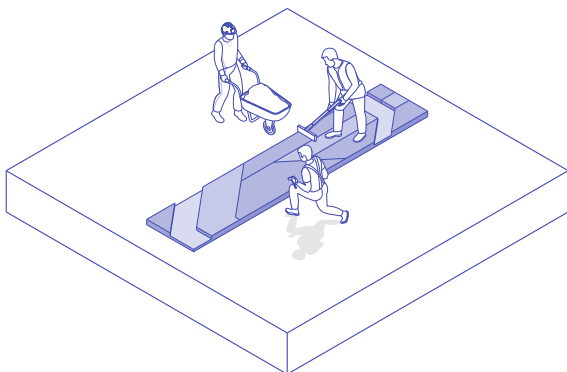
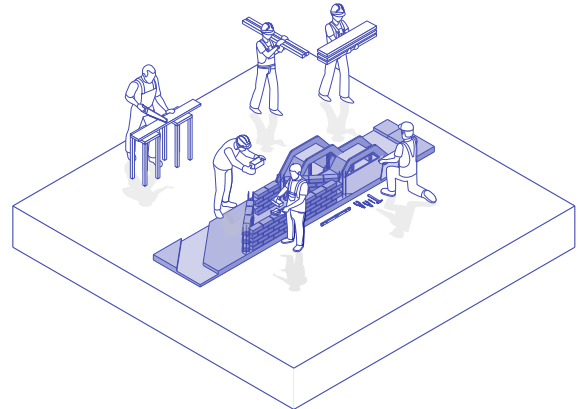
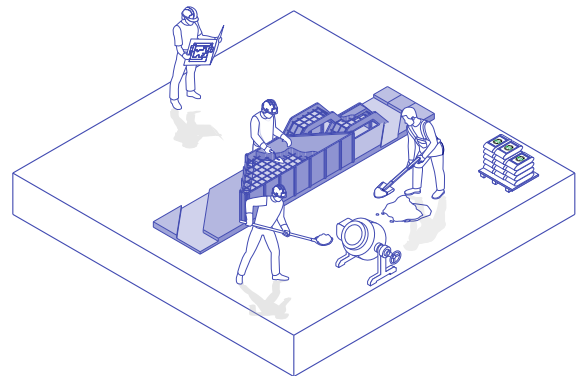
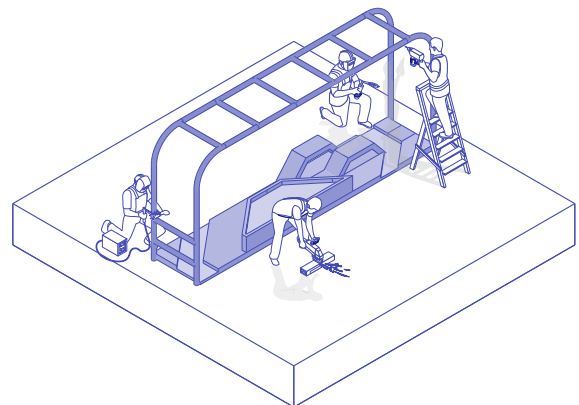
Step 1. Layout and leveling**Step 2.** Base preparation**Step 3.** Brick wall installation**Step 4.** Formwork, reinforcement, and concrete pouring**Step 5.** Removal and polishing of the concrete and installation of the metal

Learn

Semi-active zone

05

Learn

Beyond the classroom, courtyards become learning environments through outdoor teaching activities, group dynamics, or hands-on experiments.

These experiences strengthen social skills such as teamwork, assertive communication, and collaborative critical thinking.

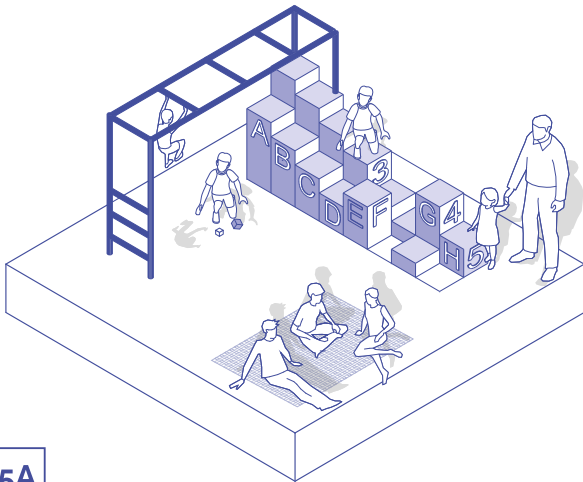

5A

Didactic play staircase

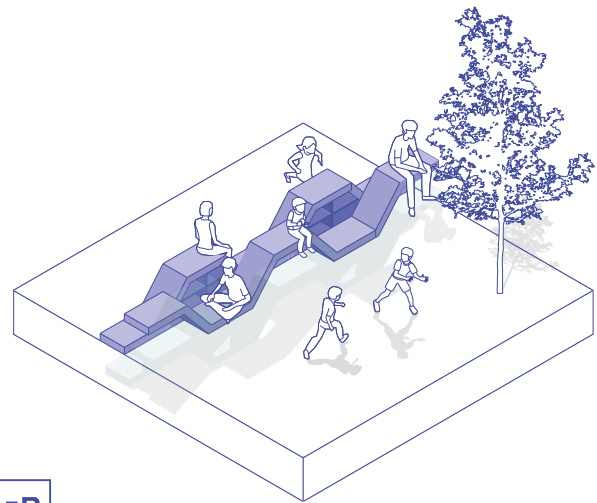

5B

Modular learning and meeting bleachers

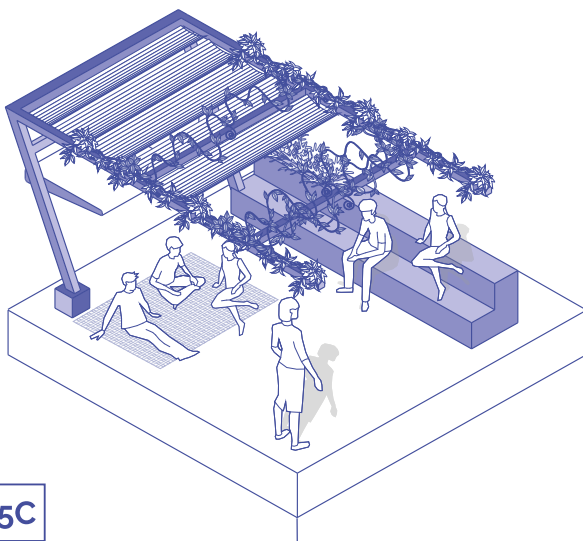

5C

Open-air classroom with pergola

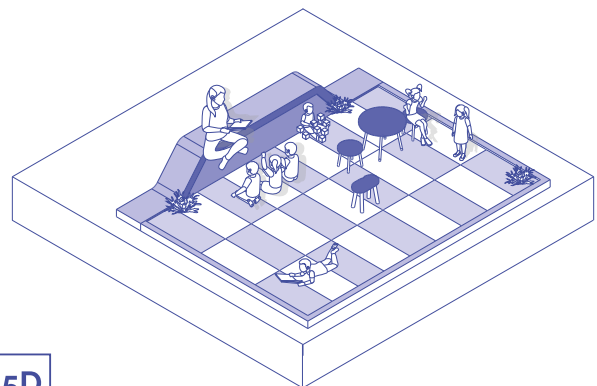

5D

Learning and strategy plaza

Didactic play staircase

Device 5A Description and construction steps

5A

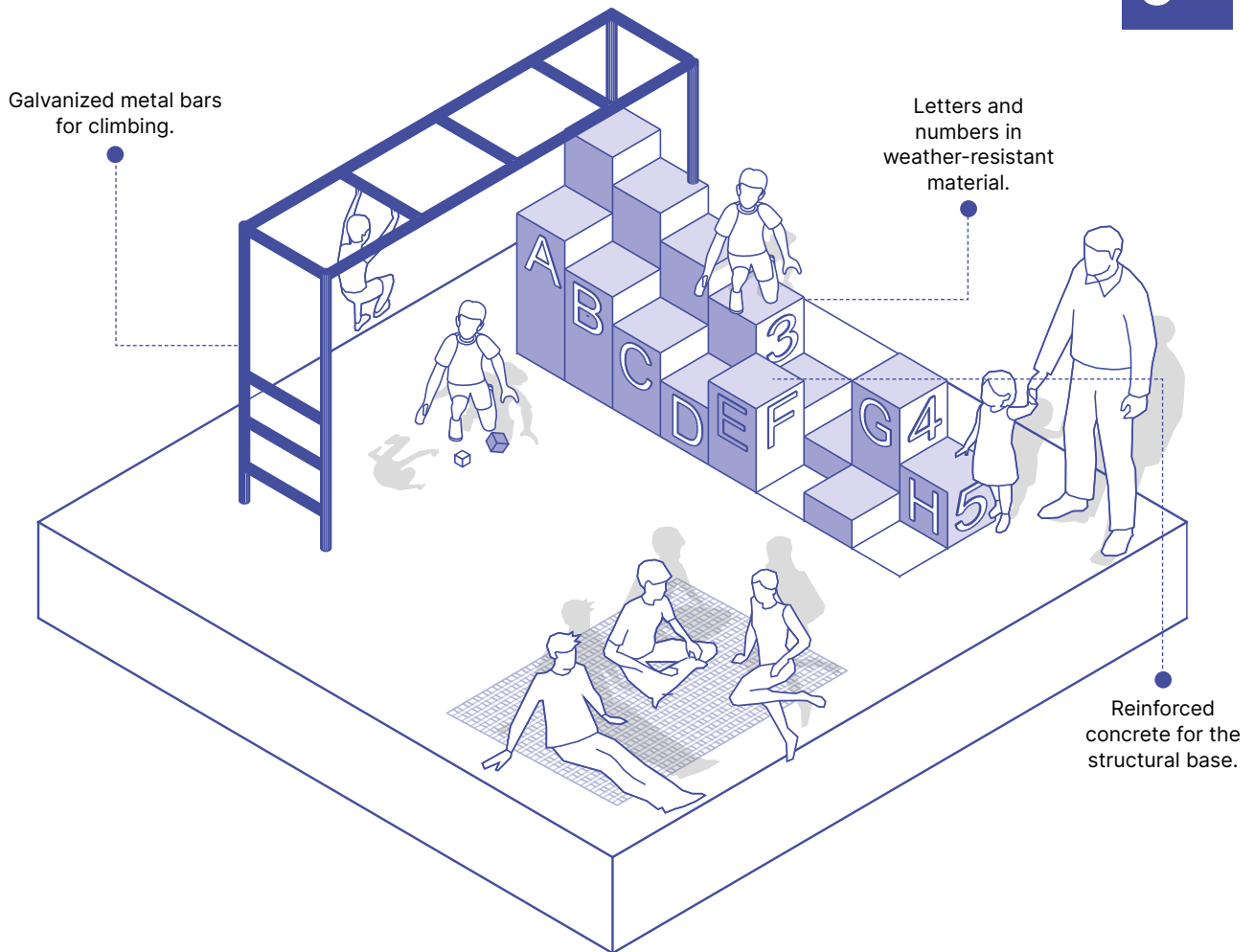

FEATURES	DESCRIPTION
Recommended use	<ul style="list-style-type: none"> • Development of motor skills through climbing up and down. • Learning and social interaction space. • Didactic tools for recognizing letters and numbers.
Users	<ul style="list-style-type: none"> • Education level: preschool and primary. • Age group: 4 to 12 years. • School community: students.
Recommended materials	<ul style="list-style-type: none"> • Reinforced concrete with textured finish for safety. • Letters and numbers in weather-resistant material. • Galvanized steel with anti-corrosion coating. • Impact-absorbing flooring in fall areas.
Suggested dimensions	<ul style="list-style-type: none"> • Total height: 1.80 – 2.20 m. • Length: 3 m. • Width: 1 m. • Step height: 20 – 50 cm.
Maintenance	<ul style="list-style-type: none"> • Regular cleaning with water and mild detergent. • Periodic inspection of the metal structure for corrosion or wear. • Repainting of didactic elements every 6 months. • Verification of impact surface cushioning.
Benefits	<ul style="list-style-type: none"> • Encourages learning through play and exploration. • Improves gross motor skills. • Promotes social interaction and teamwork.

Device 5A **Didactic play staircase****5A**

This device combines learning and physical activity through a staircase with letters and numbers on its steps, encouraging recognition and association of concepts through movement.

It incorporates a metal climbing structure that stimulates gross motor skills and social interaction. Designed to be integrated into semi-active zones, it functions as both a learning tool and a gathering point within the school courtyard. Below are the construction steps:

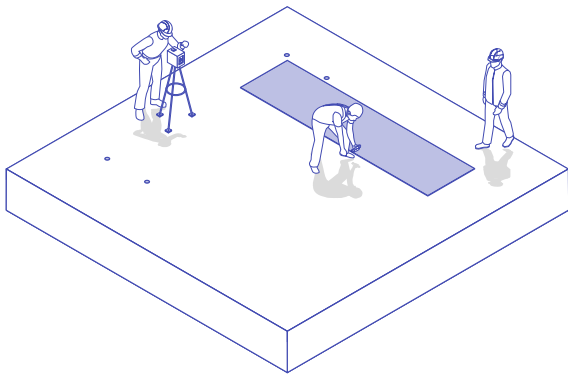
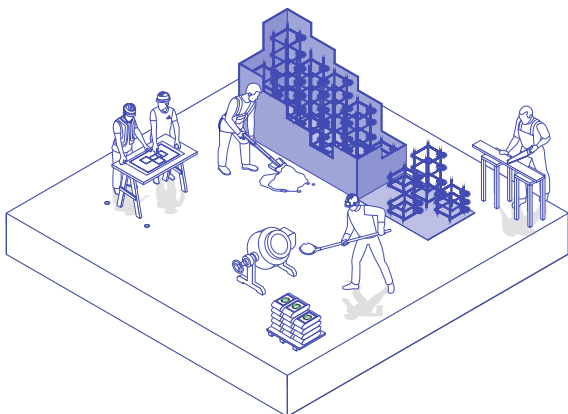
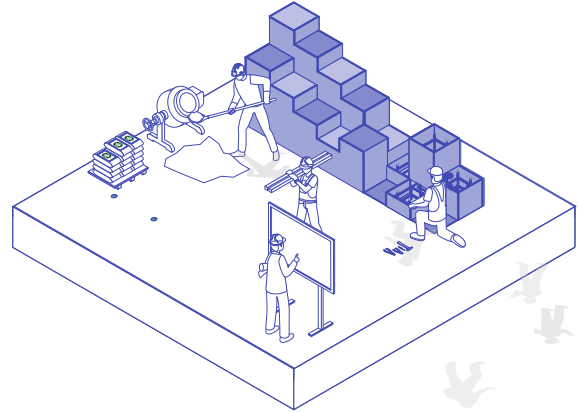
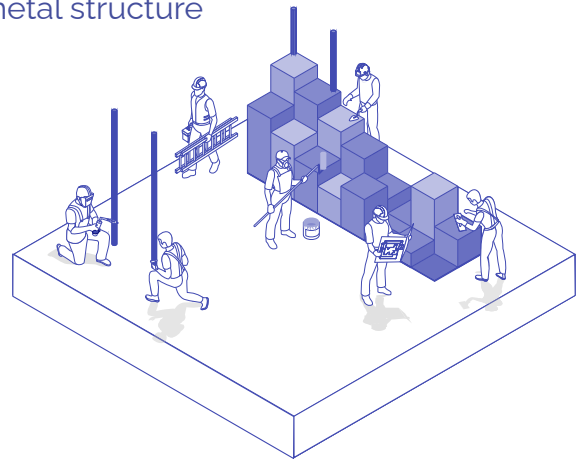
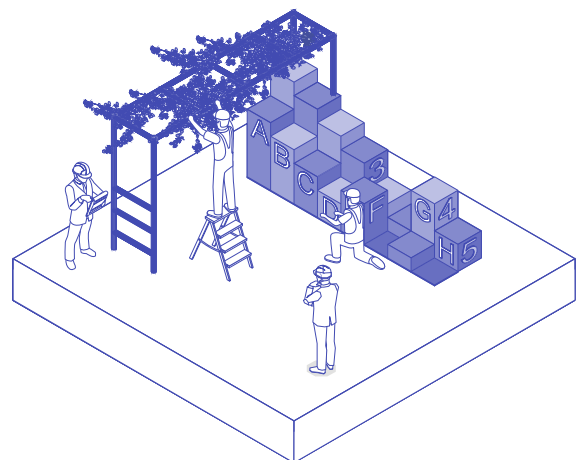
Step 1. Layout and leveling**Step 2.** Base preparation**Step 3.** Formwork, reinforcement, and concrete pouring**Step 4.** Painting and installation of the metal structure**Step 5.** Installation of vegetation

Modular learning and meeting bleachers

Device 5B Description and construction steps

5B

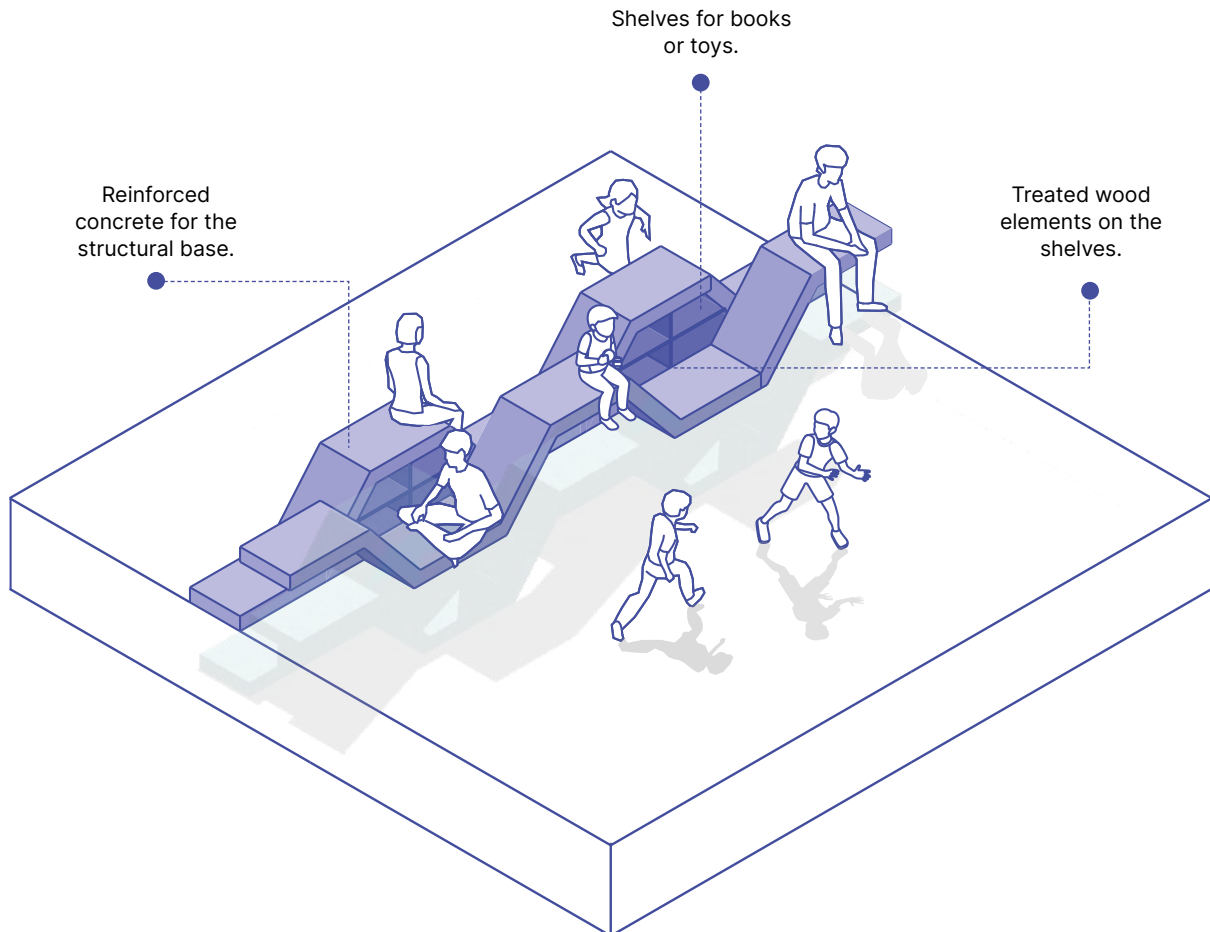

FEATURES	DESCRIPTION
Recommended use	<ul style="list-style-type: none"> • Outdoor learning classes and dynamics. • Reading and study space. • Group gatherings and recreational activities.
Users	<ul style="list-style-type: none"> • Education level: primary and secondary. • Age group: 6 to 17 years. • School community: students and teachers.
Recommended materials	<ul style="list-style-type: none"> • Reinforced concrete for the structure. • Non-slip surface on steps. • Treated wood elements on the shelves for added comfort.
Suggested dimensions	<ul style="list-style-type: none"> • Length: 3 – 6 m. • Width: 1 m. • Height: 0.8 – 1.2 m.
Maintenance	<ul style="list-style-type: none"> • Regular cleaning of surfaces. • Structural inspection every 6 months. • Weather protection to ensure durability.
Benefits	<ul style="list-style-type: none"> • Encourages learning in a dynamic environment. • Facilitates interaction and teamwork. • Optimizes the use of school space for multiple activities.

Device 5B **Modular learning and meeting bleachers****5B**

This device is designed as an outdoor learning space, combining concrete bleachers with areas for reading and social interaction. Its modular structure allows for a variety of uses, from informal classes to group gatherings.

The tiered layout enhances visibility and interaction, promoting a more flexible and inclusive learning environment within the schoolyard. Below are the construction steps:

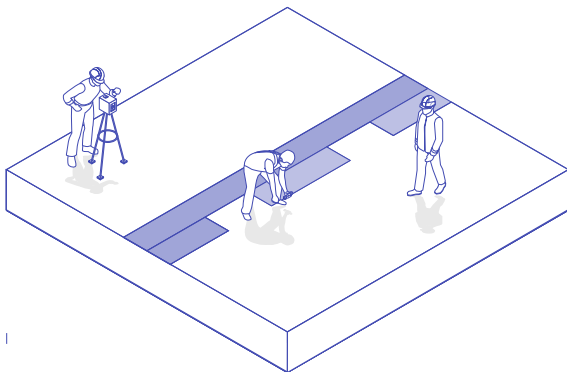
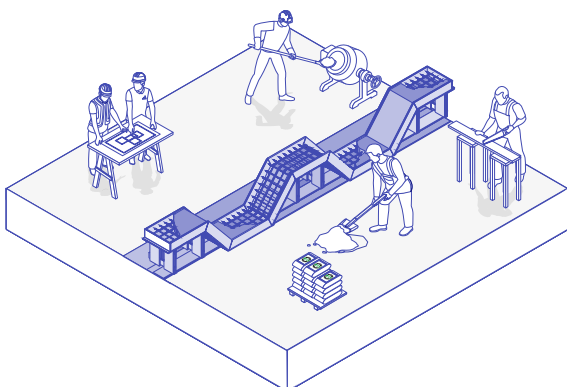
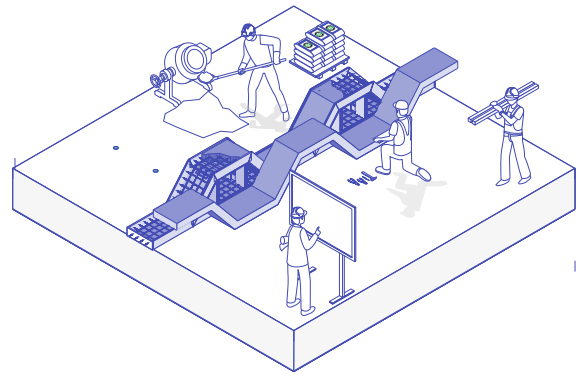
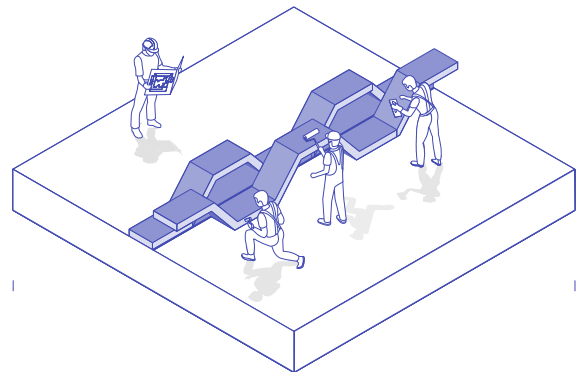
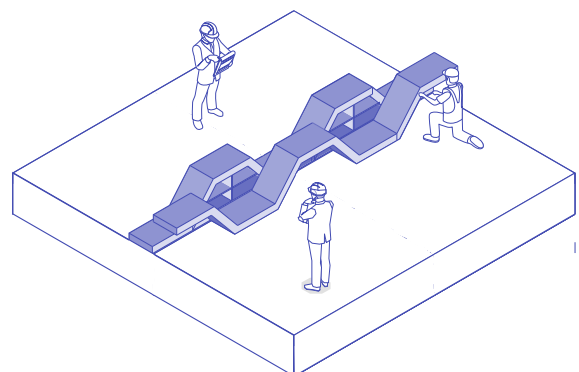
Step 1. Layout and leveling**Step 2.** Base preparation**Step 3.** Formwork, reinforcement and concrete pouring**Step 4.** Formwork removal and concrete finishing**Step 5.** Installation of wooden shelves

Rest

Quiet zone

06

Rest

Courtyards provide a space for pause, where students can relax by sitting on benches or simply enjoy a moment of calm. This fosters emotional well-being and also helps develop social skills such as self-regulation, empathy, and respect for others' personal space.

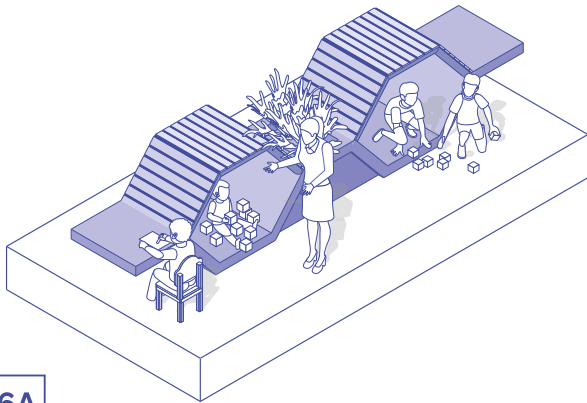
**6A**

Modular rest shelter

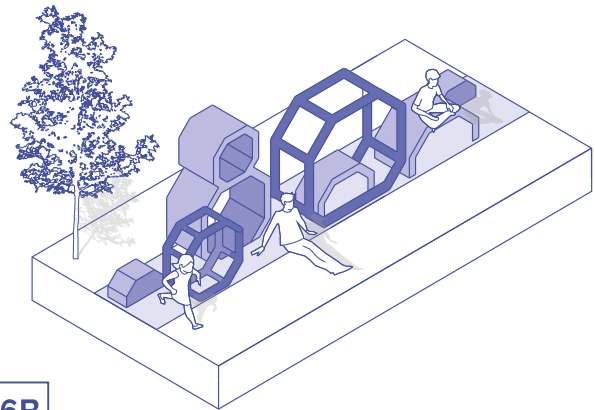
**6B**

Rest and play capsules

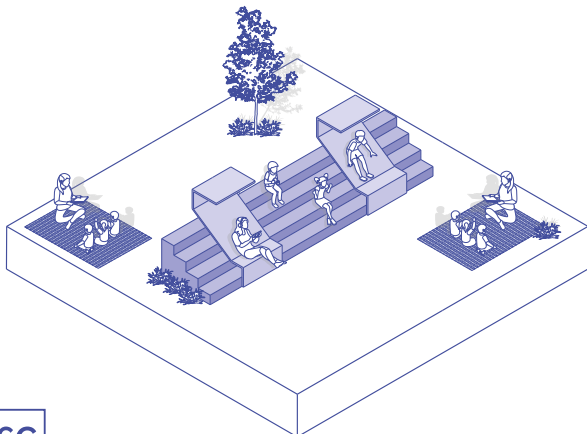
**6C**

Rest and meeting bleachers

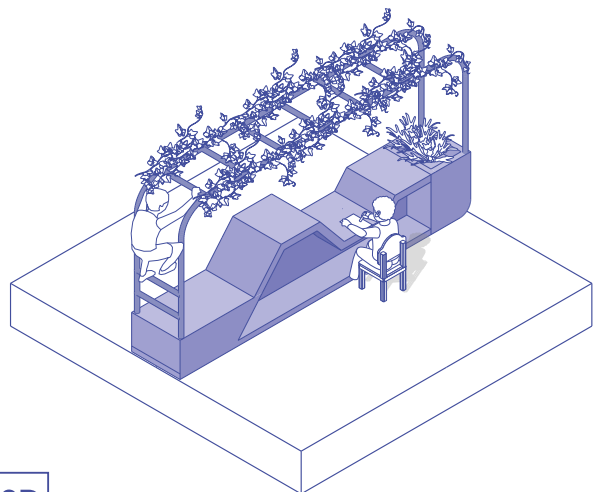
**6D**

Modular relaxation pergola

Modular rest shelter

Device 6A Description and construction steps

6A

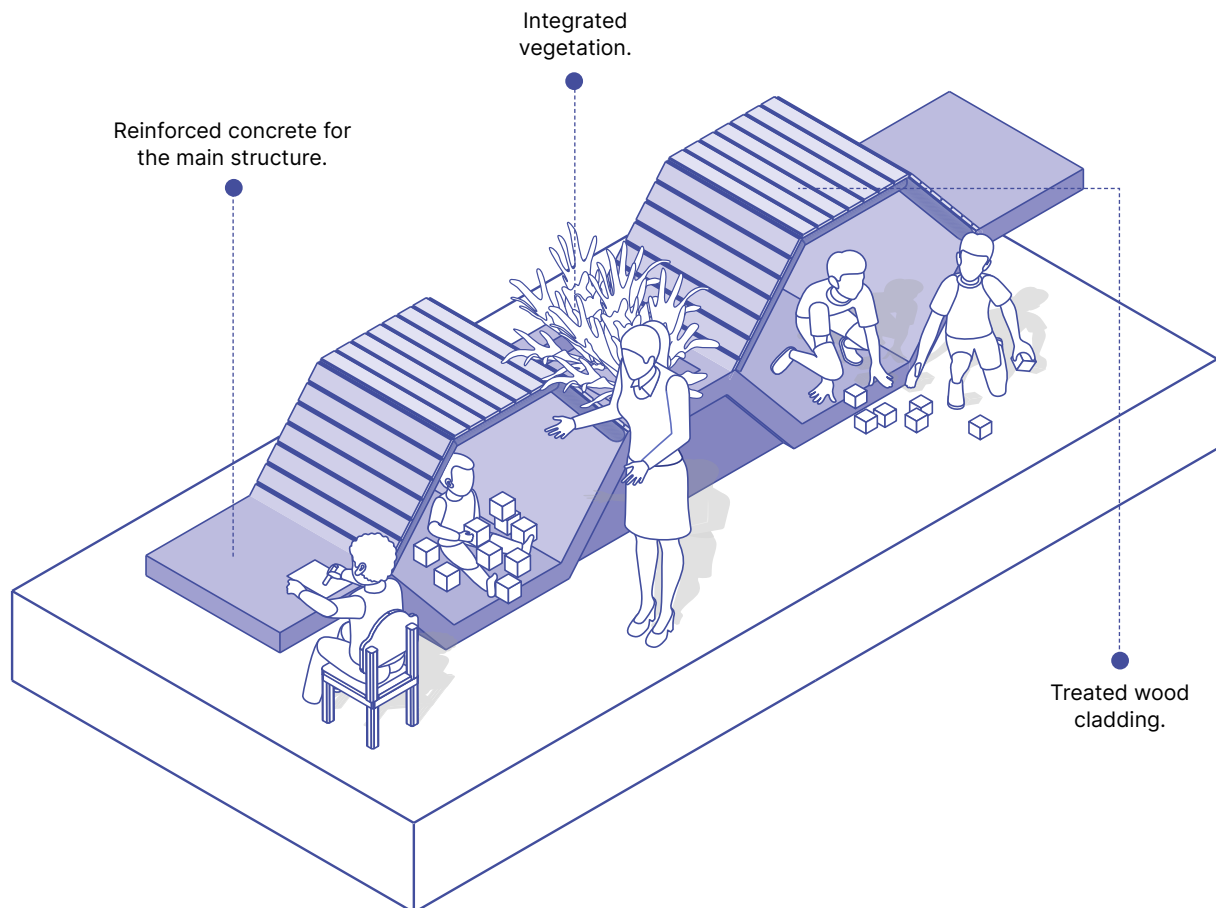

FEATURES	DESCRIPTION
Recommended use	<ul style="list-style-type: none"> • Rest and relaxation area. • Reading and conversation space. • Quiet play and sensory exploration area.
Users	<ul style="list-style-type: none"> • Education level: preschool, primary, and secondary. • Age group: 4 to 17 years. • School community: students and teachers.
Recommended materials	<ul style="list-style-type: none"> • Reinforced concrete for the main structure. • Galvanized metal elements for supports. • Treated wood cladding. • Integrated vegetation for natural shade.
Suggested dimensions	<ul style="list-style-type: none"> • Length: 3 – 6 m. • Width: 1 m. • Height: 1.3 m.
Maintenance	<ul style="list-style-type: none"> • Regular cleaning of benches and surfaces. • Structural inspection every 6 months. • Pruning and maintenance of vegetation.
Benefits	<ul style="list-style-type: none"> • Provides a space for rest and protection. • Encourages quiet interaction and play. • Improves environmental comfort through shade and natural ventilation.

Device 6A **Modular rest shelter****6A**

This device is designed as a rest and social interaction space within the school courtyard. Its reinforced concrete and metal structure ensures durability, while its wooden cladding provides thermal comfort.

It includes integrated benches and vegetation to create a shaded and welcoming area, ideal for reading, conversation, and relaxation. Its modular design allows for different configurations, offering a safe and comfortable environment for students. Below are the construction steps:

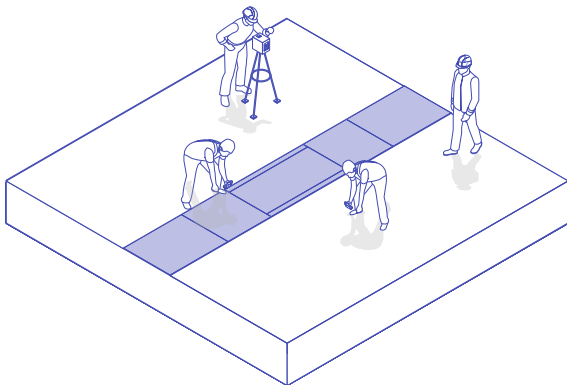
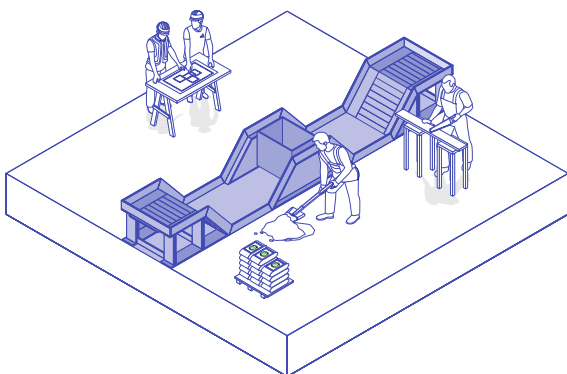
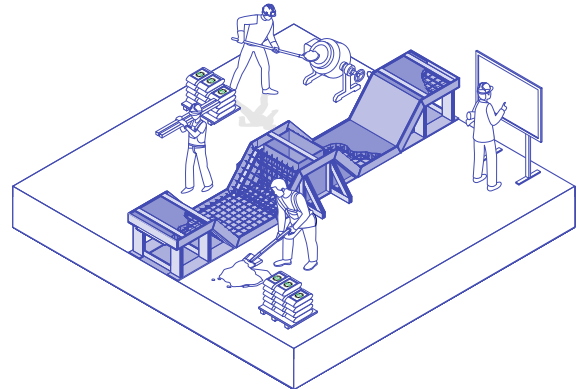
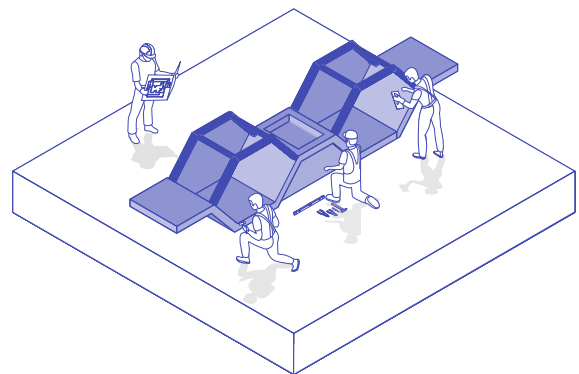
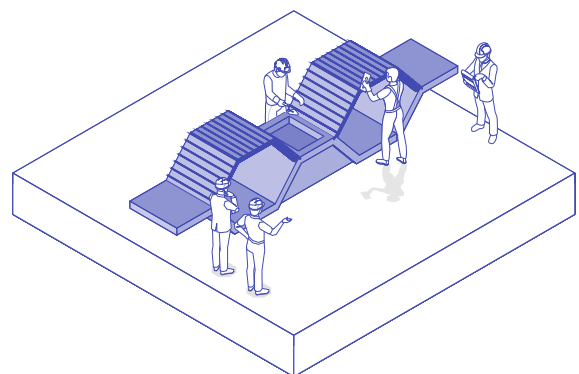
Step 1. Layout and leveling**Step 2.** Base preparation**Step 3.** Formwork, reinforcement, and concrete pouring**Step 4.** Installation of the metal structure**Step 5.** Installation of wood cladding

Rest and play capsules

Device 6B Description and construction steps

6B

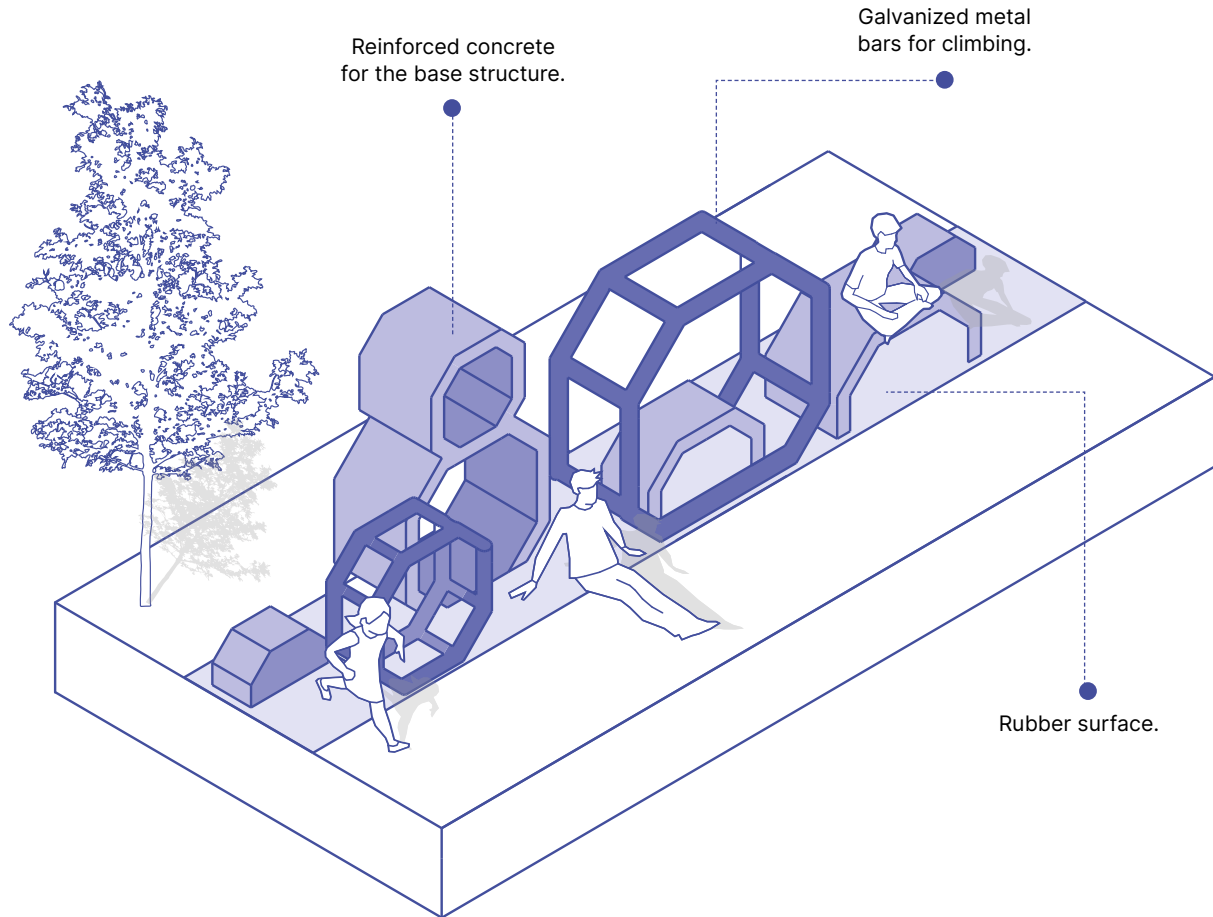

FEATURES	DESCRIPTION
Recommended use	<ul style="list-style-type: none"> • Rest and relaxation area. • Play and exploration space. • Meeting and social interaction point.
Users	<ul style="list-style-type: none"> • Education level: primary and secondary. • Age group: 6 to 17 years. • School community: students and teachers.
Recommended materials	<ul style="list-style-type: none"> • Reinforced concrete for the base structure. • Wood or recycled plastic elements for seating. • Rubber or cushioned surface for comfort and safety.
Suggested dimensions	<ul style="list-style-type: none"> • Length: 6 m. • Width: 0.5 – 1 m. • Height: 2 m.
Maintenance	<ul style="list-style-type: none"> • Regular cleaning of surfaces and modules. • Structural inspection every 6 months. • Protection against weather conditions to ensure durability.
Benefits	<ul style="list-style-type: none"> • Provides a versatile space for rest and play. • Encourages social interaction and exploration. • Improves comfort and safety for users.

Device 6B **Rest and play capsules****6B**

This device offers an innovative alternative for rest and exploration within the school courtyard. Its structure consists of interconnected geometric modules that allow users to sit, lie down, and climb in a safe environment.

Designed to provide comfort and stimulate interaction, it is ideal for relaxation, conversation, and passive play within the school courtyard. Below are the construction steps:

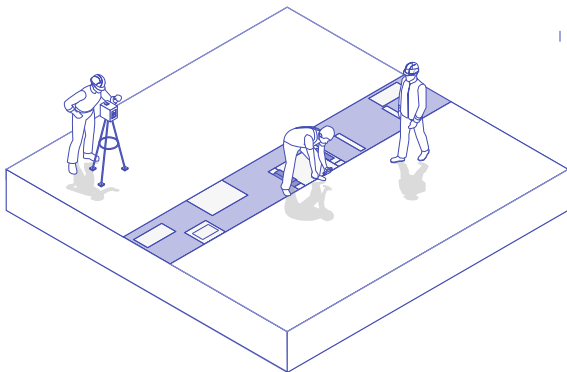
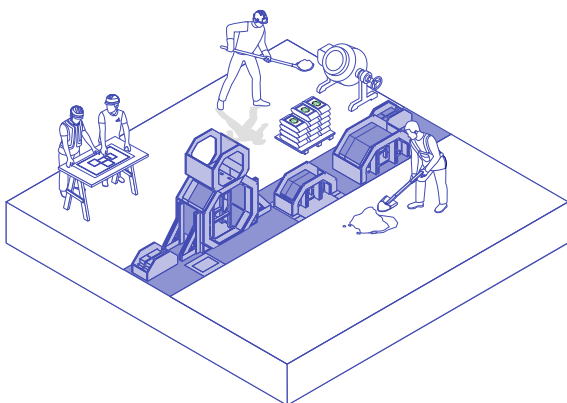
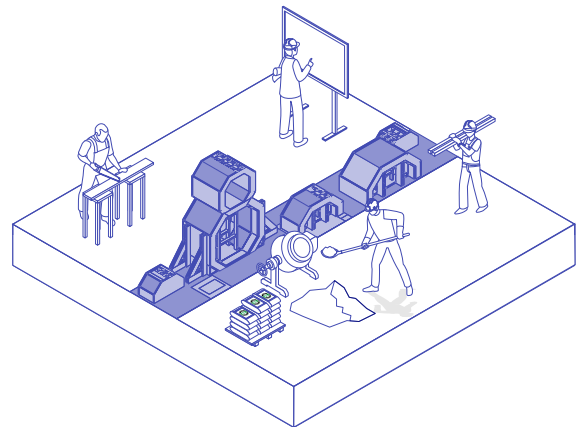
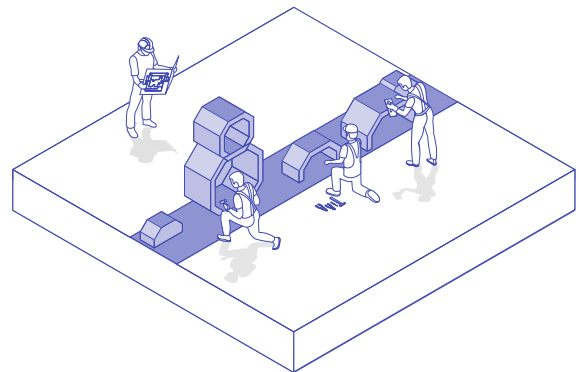
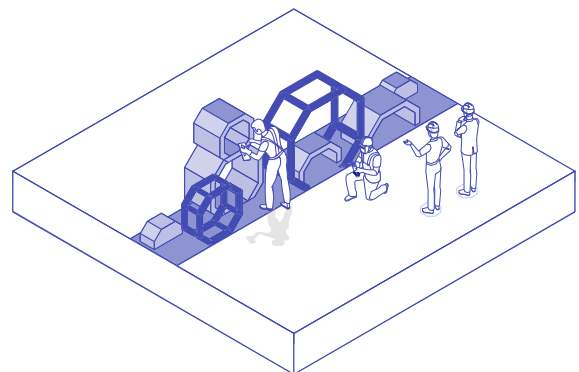
Step 1. Layout and leveling**Step 2.** Base preparation**Step 3.** Formwork, reinforcement, and concrete pouring**Step 4.** Removal and polishing of the concrete**Step 5.** Installation of the metal structure

Eat

Quiet zone

07

Eat

During recess, courtyards often become spaces where students enjoy their snacks or meals, whether in designated areas or informally. This moment contributes to socialization and the enjoyment of food, while also fostering social skills such as coexistence, respect, and interpersonal communication.

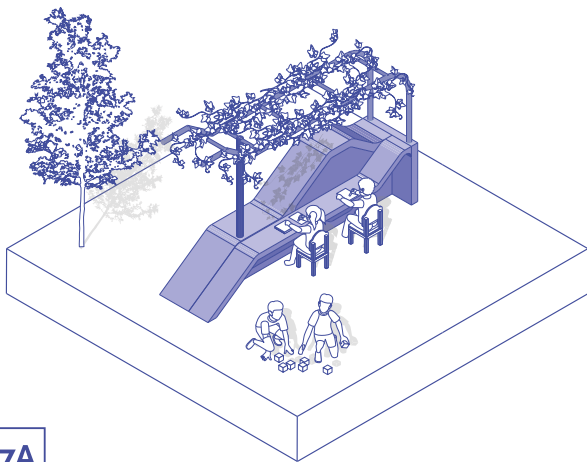

7A

Dining and meeting table

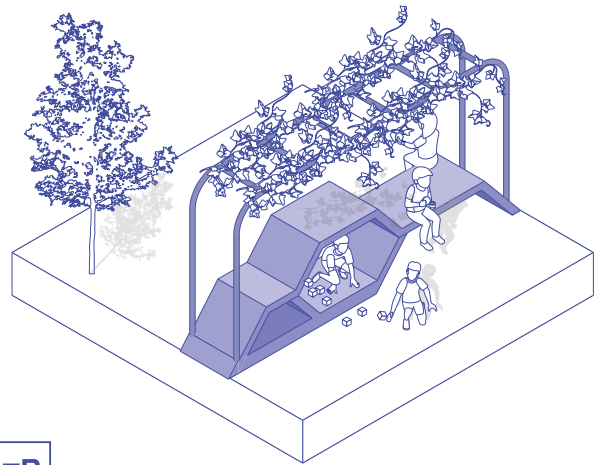

7B

Multifunctional pergola for eating

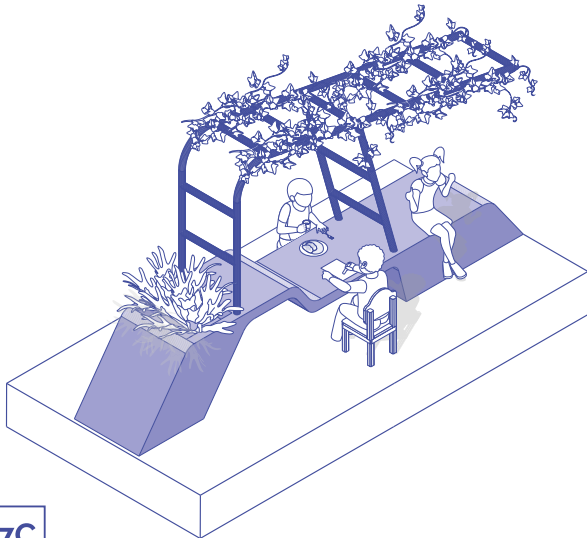

7C

Pergola dining table

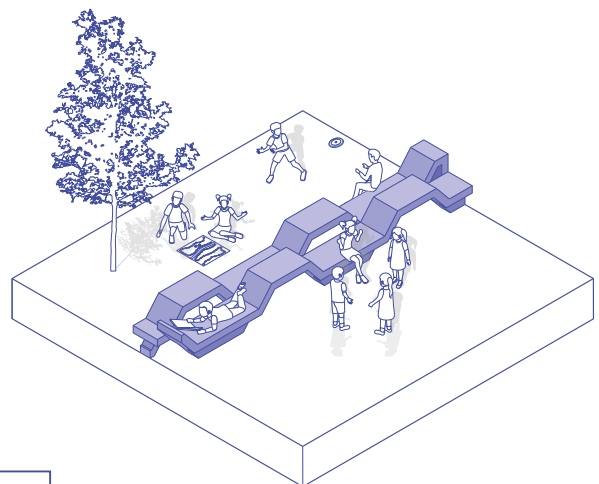

7D

Longitudinal dining and meeting module

Dining and meeting table

Device 7A Description and construction steps

7A

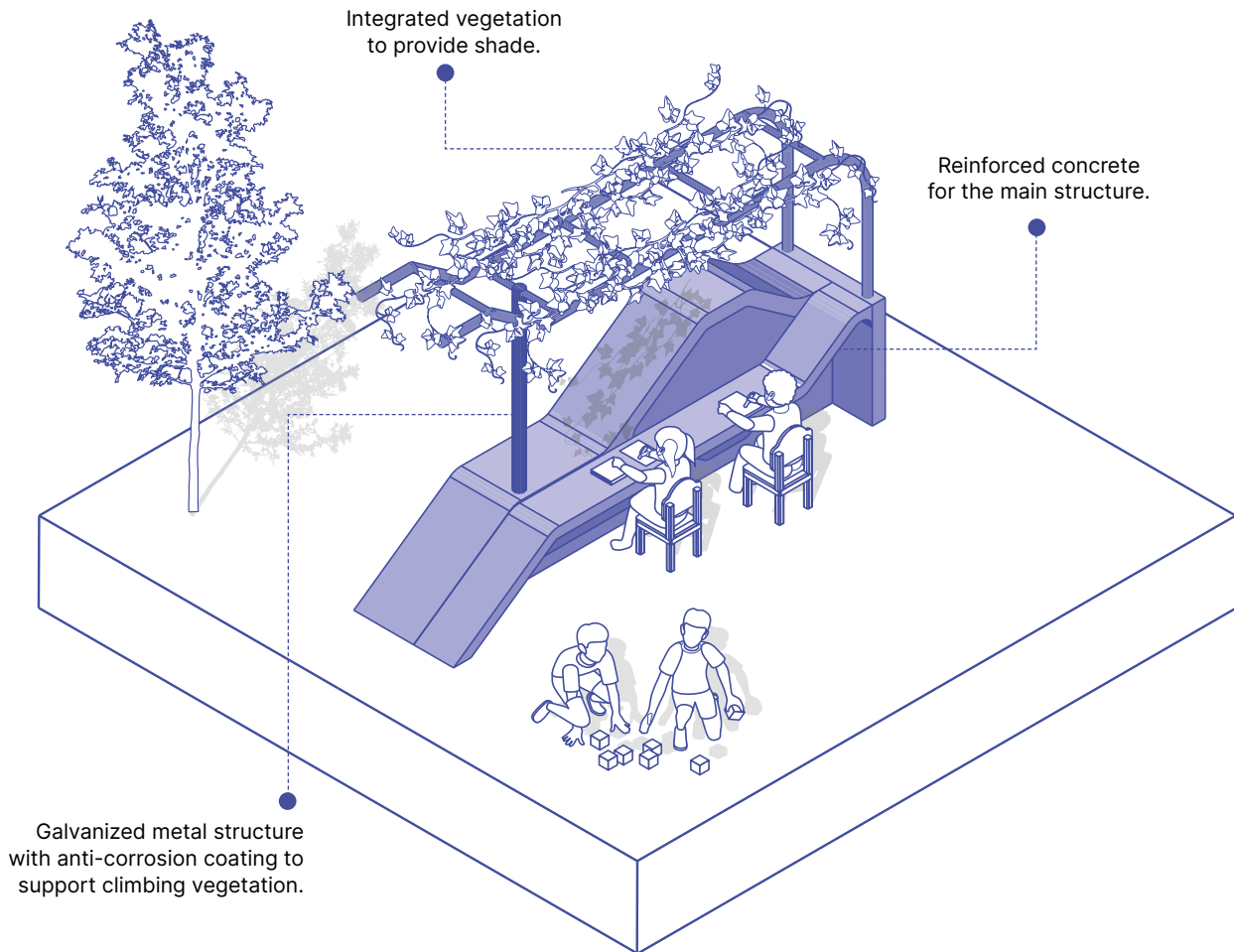

FEATURES	DESCRIPTION
Recommended use	<ul style="list-style-type: none"> Dining and recreation area. Social interaction and rest space. Outdoor activities area.
Users	<ul style="list-style-type: none"> Education level: preschool, primary, and secondary. Age group: 4 to 17 years. School community: students and teachers.
Recommended materials	<ul style="list-style-type: none"> Reinforced concrete for the structure. Galvanized metal elements for pergola and supports. Integrated vegetation for shade.
Suggested dimensions	<ul style="list-style-type: none"> Length: 3 m. Width: 1 m. Height: 1.2 – 1.5 m.
Maintenance	<ul style="list-style-type: none"> Regular cleaning of tables and benches. Structural inspection every 6 months. Pruning and maintenance of vegetation.
Benefits	<ul style="list-style-type: none"> Provides a suitable space for eating. Encourages social interaction and outdoor rest. Improves thermal comfort through natural shade.

Device 7A **Dining and meeting table****7A**

This device is designed as a space for eating and social interaction within the school courtyard. Its concrete and metal structure integrates tables and benches protected by a pergola with vegetation, providing shade and thermal comfort.

Its inclined design allows for a dynamic and flexible layout, encouraging interaction among students and creating a pleasant environment for meals and group activities. Below are the construction steps:

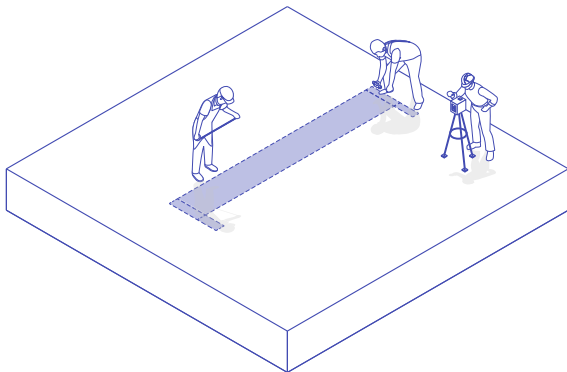
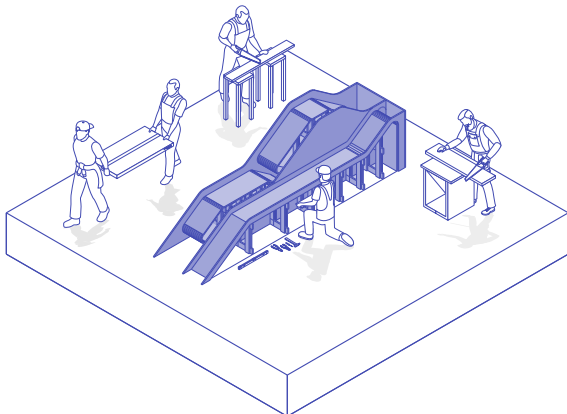
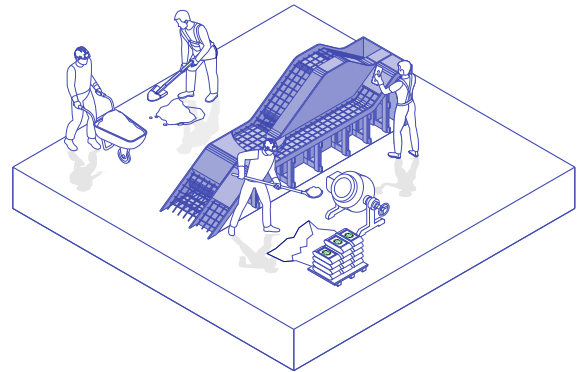
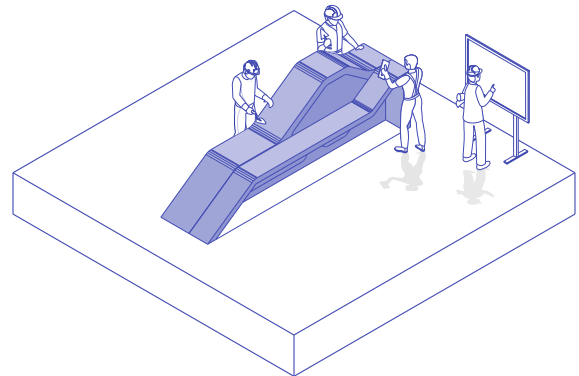
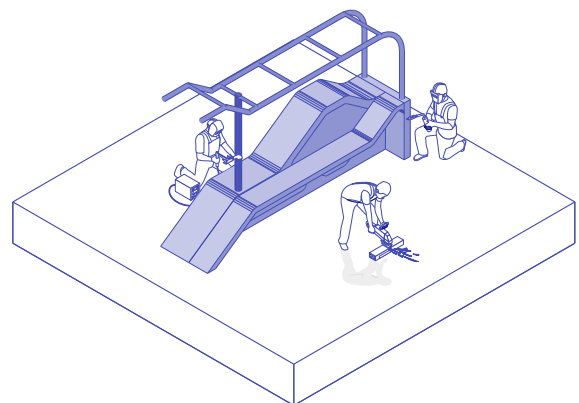
Step 1. Layout and leveling**Step 2.** Base preparation**Step 3.** Formwork, reinforcement, and concrete pouring**Step 4.** Removal and polishing of the concrete**Step 5.** Installation of the metal structure

Multifunctional pergola for eating

Device 7B Description and construction steps

7B

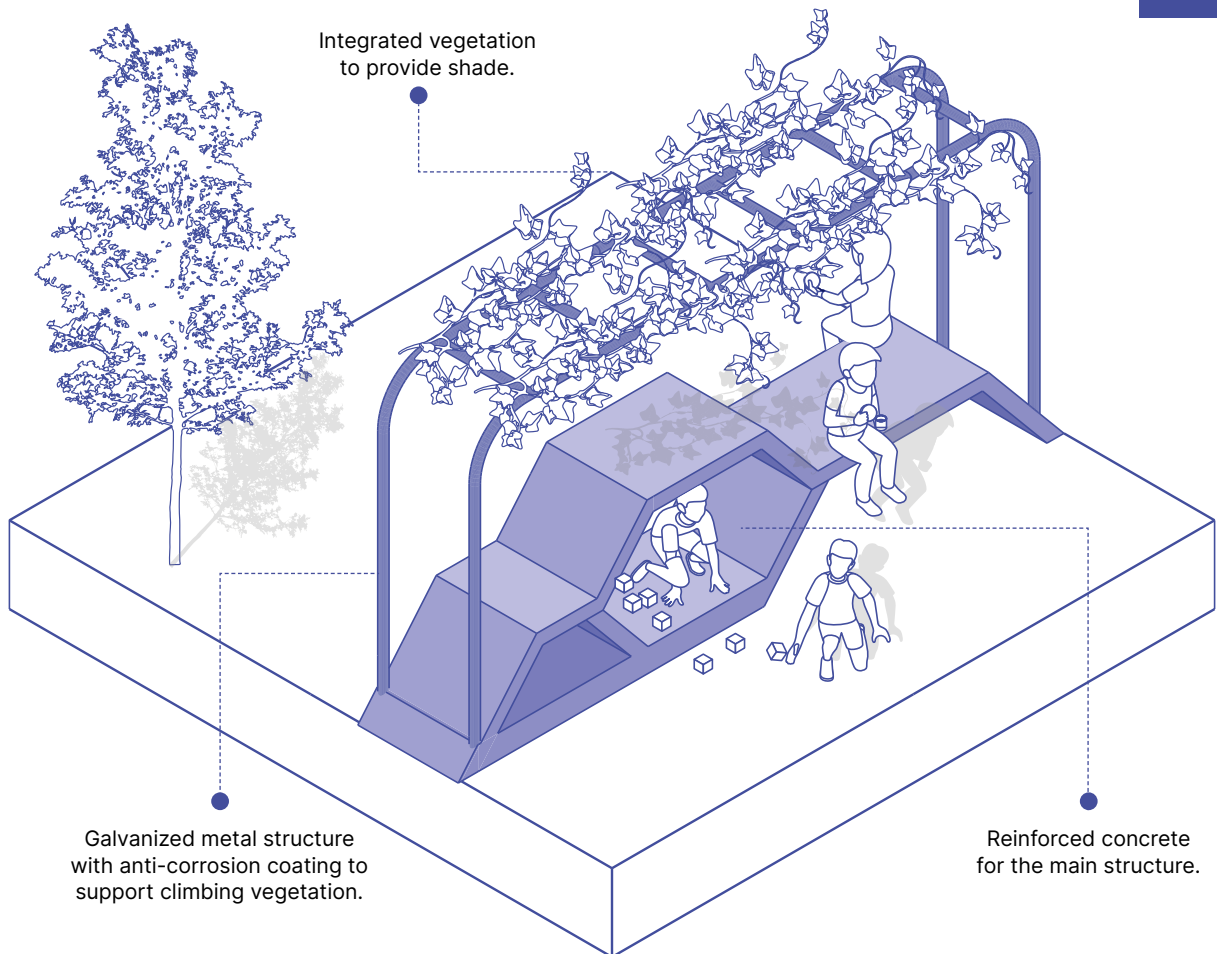

FEATURES	DESCRIPTION
Recommended use	<ul style="list-style-type: none"> • Dining and recreation area. • Rest and social interaction space. • Outdoor educational activities area.
Users	<ul style="list-style-type: none"> • Education level: preschool, primary, and secondary. • Age group: 4 to 17 years. • School community: students and teachers.
Recommended materials	<ul style="list-style-type: none"> • Reinforced concrete for benches and surfaces. • Metal structures for pergola and supports. • Climbing vegetation to provide shade and freshness.
Suggested dimensions	<ul style="list-style-type: none"> • Length: 3 m. • Width: 1 m. • Height: 1.2 – 1.5 m.
Maintenance	<ul style="list-style-type: none"> • Regular cleaning of surfaces and furniture. • Structural inspection every 6 months. • Pruning and maintenance of vegetation.
Benefits	<ul style="list-style-type: none"> • Provides a pleasant and protected space for eating. • Encourages integration and student interaction. • Creates a comfortable microclimate through integrated vegetation.

Device 7B **Multifunctional pergola for eating****7B**

This device combines rest and dining spaces within a single structure. Its concrete design integrates benches and surfaces for eating, protected by a pergola with vegetation.

In addition to being a space for meals, it adapts to activities such as reading and conversation, promoting integration and well-being in a fresh and comfortable environment within the school courtyard. Below are the construction steps:

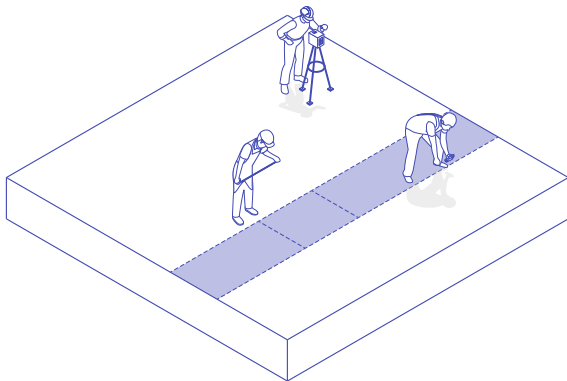
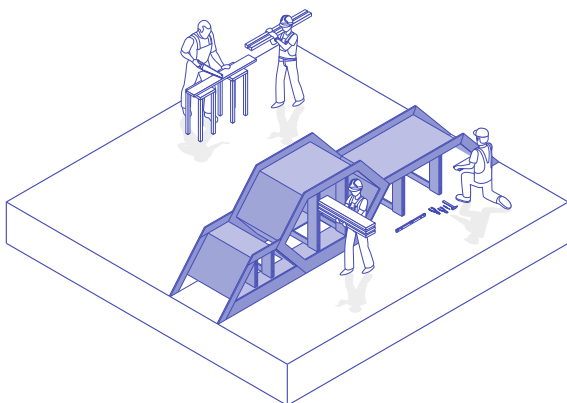
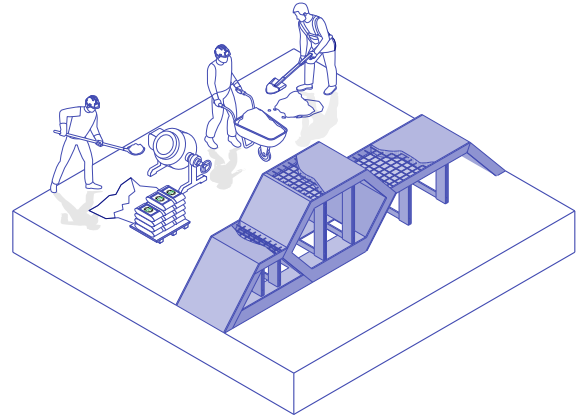
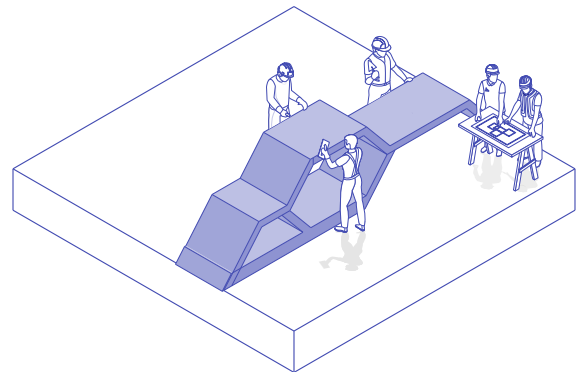
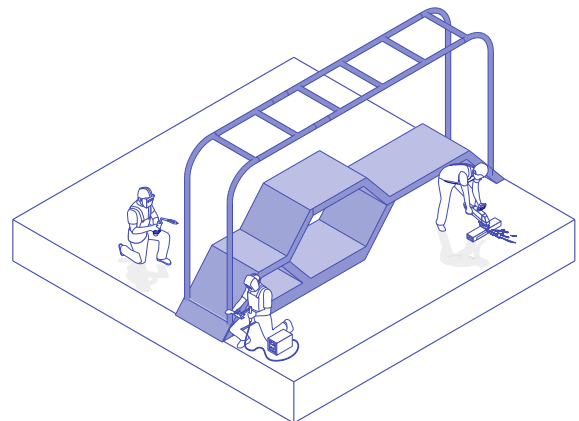
Step 1. Layout and leveling**Step 2.** Base preparation**Step 3.** Formwork, reinforcement, and concrete pouring**Step 4.** Removal and polishing of the concrete**Step 5.** Installation of the metal structure



Connectors

Connector devices

Below are the connector devices that allow the configuration of different elements and their adaptation to the context.

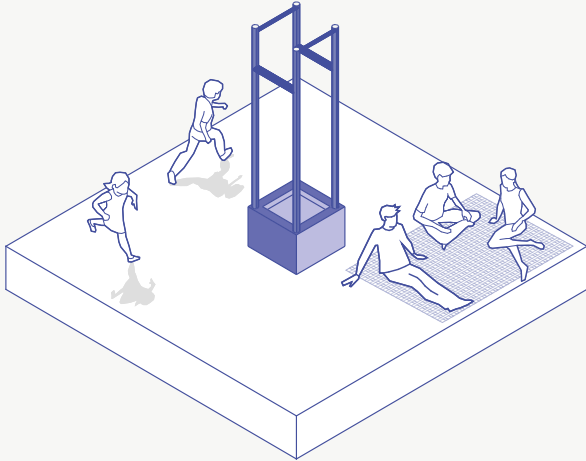

Column with concrete base and metal structure

A structural element that connects various devices, offering vertical support. Its design allows spatial continuity and definition without obstructing circulation.

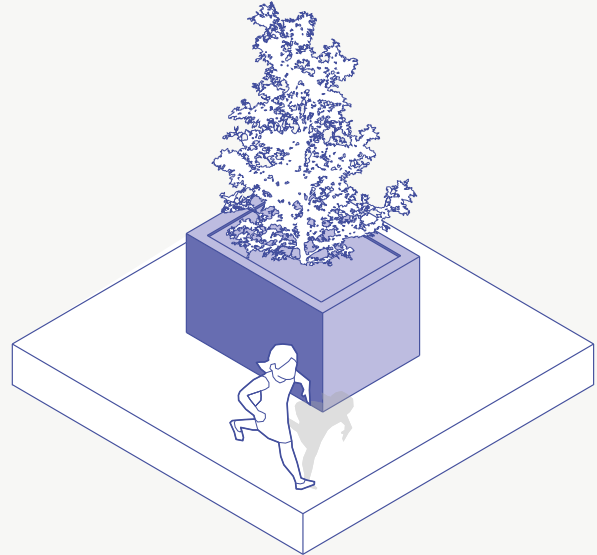

Connector planter for joints between devices and longitudinal layouts

A concrete element that enables the integration of devices in aligned configurations, providing spatial continuity. Its vegetation improves thermal and environmental comfort.

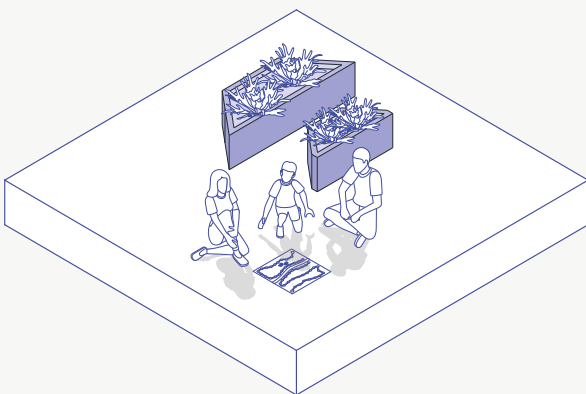

Trapezoidal planter connector for corners

A connector that allows the integration of devices at angles, adapting to corners and generating areas of vegetation for shade and natural ambience.

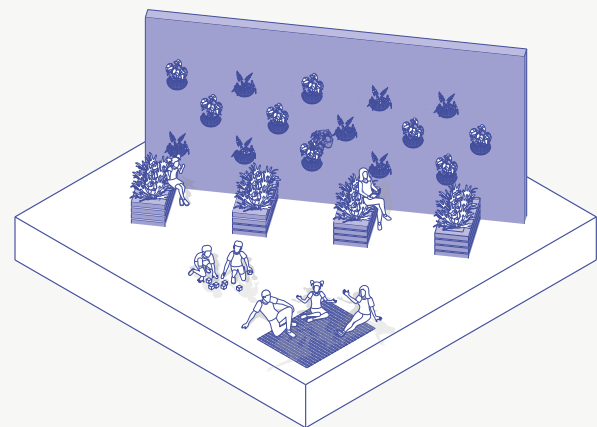

Connectors can also be used independently as planters

Modular elements that function autonomously as planters, providing vegetation and spatial definition without the need to connect to other devices.

4

Design Suggestions

The design of the school courtyard influences students' learning, recreation, and interaction dynamics. In this section, we explore three innovative layout configurations: The Ribbon, The Circle, and Pixels, each designed to respond to different needs and foster a more inclusive, dynamic, and functional environment.

Discover how to transform your courtyard into a space that promotes the development of students' social skills, increasing their chances of becoming well-rounded and successful adults.

Design suggestions

In this section of the toolkit, we present three configuration options for a school courtyard, each with a distinct approach to optimize space and encourage interaction.



The Ribbon

A linear design that organizes activities along a route, allowing a fluid transition between active, semi-active, and quiet zones.



The Circle

A design centered on coexistence and interaction, where activities revolve around a focal point that supports integration and equitable use of space.

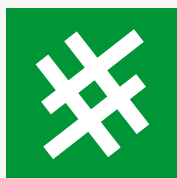

The Pixels

A modular approach based on fragmenting the space into small defined areas that can adapt to different activities and needs.

1 The Ribbon

A linear layout that organizes activities along a continuous path, allowing for a smooth transition between active, semi-active, and quiet zones.





Do sports
and physical
education



Create art



Eat



Learn

2 The Circle

A layout centered on coexistence and interaction, where activities revolve around a focal point that promotes integration and equitable use of space.



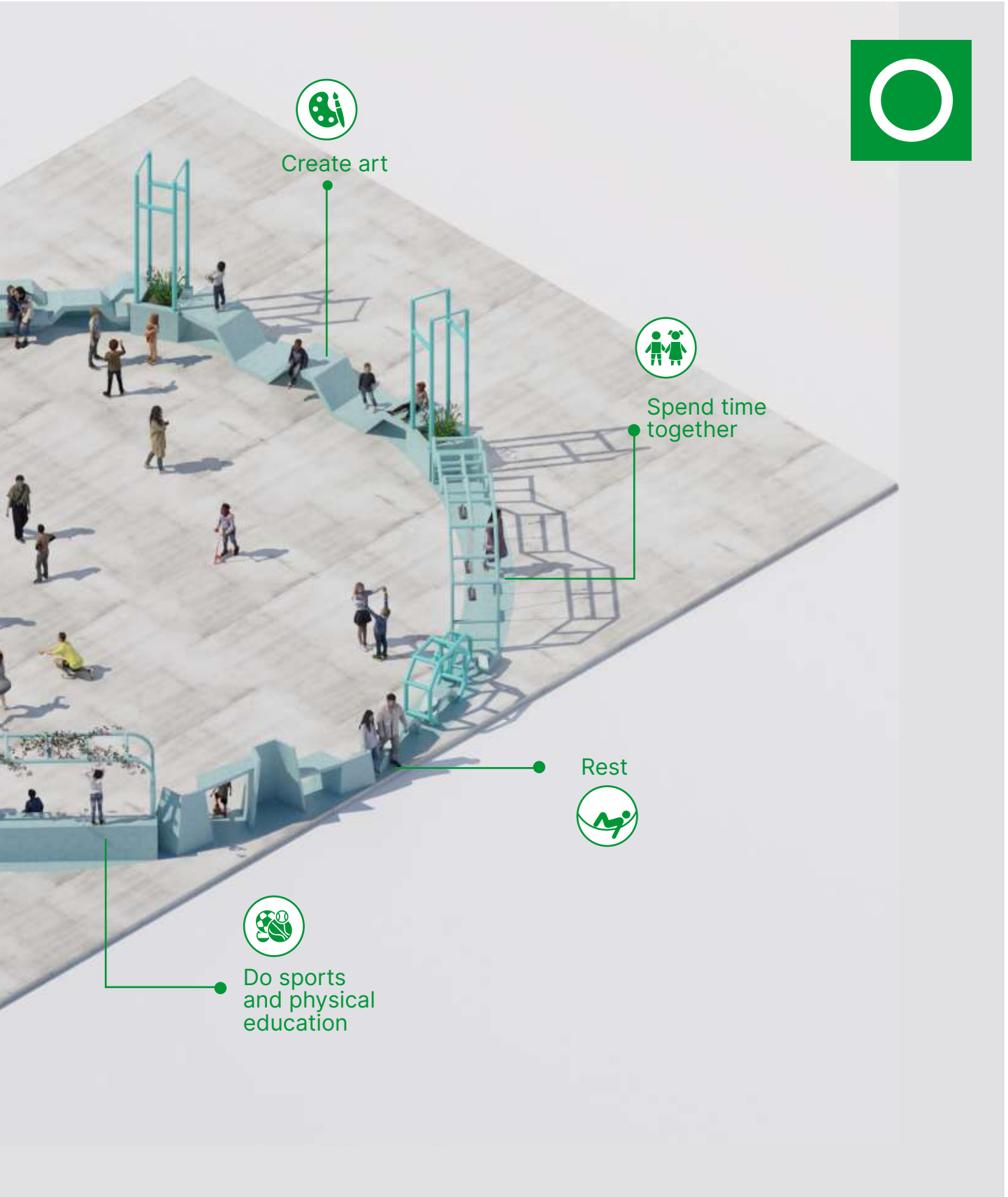

Create art



Spend time together



Rest



Do sports and physical education

3 Pixels

A modular approach based on the fragmentation of space into smaller defined areas, adaptable to different activities and needs.

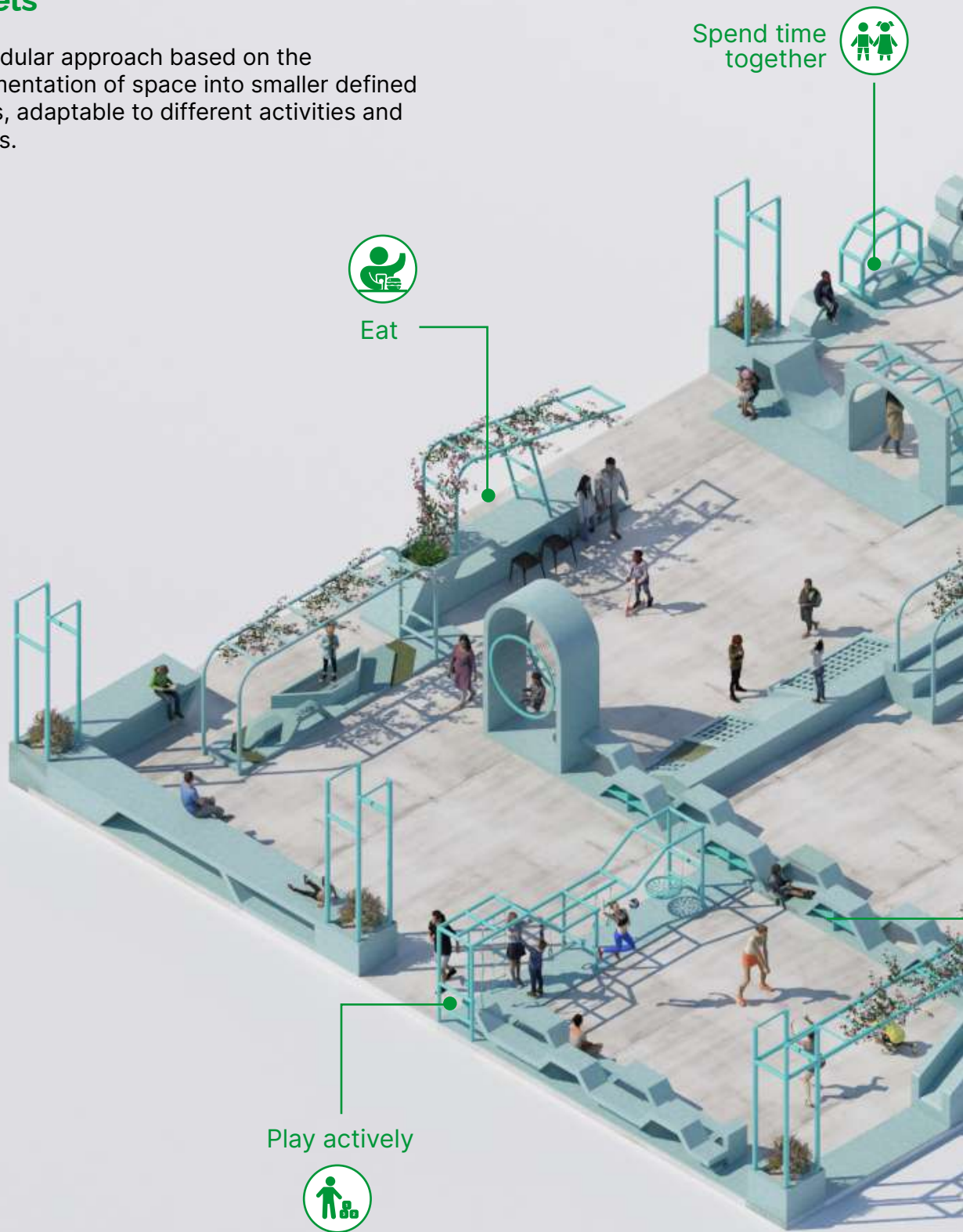

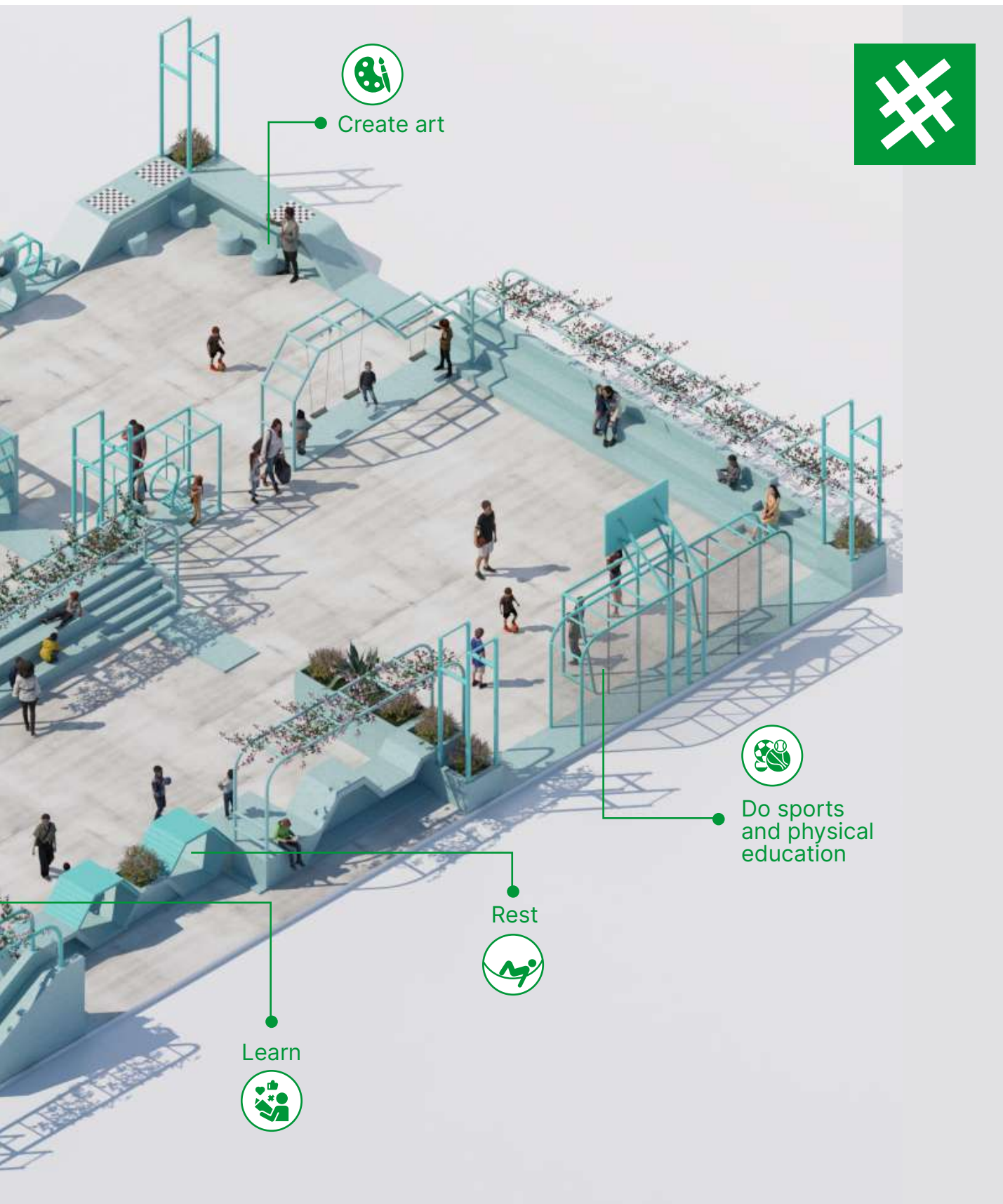

Create art



Do sports and physical education



Rest



Learn

Choose the design that best fits the shape and dimensions of your courtyard, prioritize the devices you consider essential, and start today to build an educational revolution in your school with the support of Cemento SOL.





UNACEM

<https://unacem.pe/>

<https://www.cementosol.com.pe/>